



JKP «Водовод и канализација» Суботица
JKP «Vodovod i kanalizacija» Subotica
Vízművek és Csatornázási Kommunális Közvéllalat Szabadka

24000 Subotica • Trg Lazara Nešića 9/a
Tel.: (024) 55-77-11 • Fax: (024) 55-77-00 • e-mail: uprava@vodovodsu.rs



Broj: 45/11-120-2015

Dana: 08.12.2015. godine

Na osnovu člana 63. Zakona o javnim nabavkama („Službeni glasnik RS“ broj 124/2012; 14/2015 68/2015) dostavljamo Vam

Predmet: Odgovor u vezi sa konkursnom dokumentacijom broj 45/1-78-2015 – Rezervni delovi za fabriku vode

Naručilac je dana 07.12.2015. godine primio pitanje zavedeno pod brojem 46/10-106-2015 od zainteresovanog lica koje glasi:

1. “S obzirom da nećemo nuditi opremu "EL-O-MATIC" molimo Vas da nam dostavite podatke o leptir ventilima na koje su aktuatori, opisani u tenderu, montirani. Prvenstveno mislimo na ugradne mere ka aktuatoru.

Ako ste u mogućnosti, dostavite nam podatak ko je proizvođač leptir ventila i tačnu oznaku sa natpisne pločice. Ako ste u mogućnosti, pošaljite nam fotografije natpisnih pločica sa leptir ventila na koje su aktuatori postavljeni.”

Komisija naručioca objavljuje odgovor:

- „ 1. U konkursnoj dokumentaciji na strani 33/39 Naručilac je definisao Tehničke karakteristike aktuatora: tip ED i naveo koji aktuator sa kojim leptir ventilom upravlja.

Takođe u Tehničkoj specifikaciji na strani 32/39 konkursne dokumentacije Naručilac je definisao standard priključka aktuatora sa leptir ventilom: ISO 5211.

Naručilac nije u mogućnosti da dostavi fotografije natpisnih pločica sa leptir ventila na koje su aktuatori postavljeni, iz razloga što je postojeća oprema dotrajala i ne postoje natpisne pločice sa leptir ventila na koje su aktuatori postavljeni.

Napomena: Za bliže informacije u prilogu dostavljamo tehnički list aktuatora.”

Predsednik Komisije za javnu nabavku:

Čorba Janoš el.inž. *C. J. e.*



Product Data sheets

DOC.DSE.PN.UK Rev. G

January 2012

EL-O-Matic E and P Series

Technical data pneumatic Rack and Pinion actuators



Data sheet

Sheet No.: 1.102 Rev. B
Date: January 2012

TECHNICAL DETAILS, STANDARD ACTUATOR

E/P

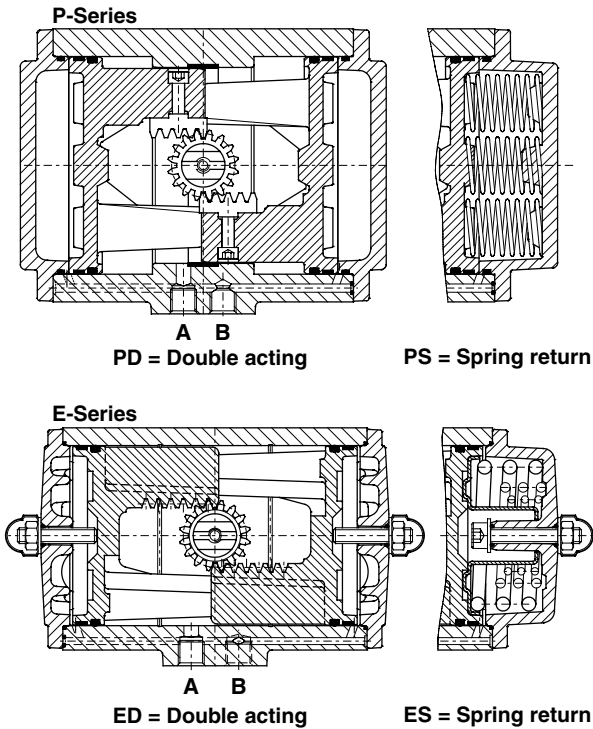

Specification

Pressure range : Double acting 0.2 to 8 bar
: Spring return 6 to 8 bar, with max. spring set
: 3 to 8 bar, reduced spring quantity

Torque : 180° actuators 6 bar g maximum
: 14.6 to 4955 Nm at 6 bar supply
See torque data sheets 1.104.01 and 1.104.02

Operating media : Air, dry or lubricated and inert gasses
: For sub-zero applications take appropriate measures

Temperature : -20° to +80°C

Lubrication : Factory lubricated for the normal life of the actuator

Construction : Suitable for indoor and outdoor installation

Finish : Polyester non-TGIC based powder coating
(see data sheet 4.204.01)

Rotation : 91.5° (-0.5° CW to 91° CCW)

Double acting : Standard counter clockwise with port "A" pressurized
(code A, see data sheet 1.503 for other assembly codes)

Spring return : Clockwise fail action
(code A, see data sheet 1.504 for other assembly codes)

Limit stops : Standard on E-Series. Adjustable range 91°/80°
: Optional on P-Series. See data sheet 1.501.01
: For double stroke adjustment. See data sheet 1.501.05

European Directives

PED : All actuators are suitable for use with Group 2 gasses according to Pressure Equipment Directive 97/23/EC
: Optional : actuators suitable for use with Group 1 gasses

ATEX : All basic actuators are suitable for use in hazardous area's classified II 2 GD, zones 1 or 2 (Gasses) and 21 or 22 (Dust)

Russian Approvals

EI-O-Matic E and P series pneumatic actuators are available with the GOST-R and Rostechnadzor (RTN) approvals.

Note

1. Operating time is average with actuator under load and solenoid valve fitted.
2. Air consumption is the actual free air volume at 1 atm.
3. Pressure is in barg.

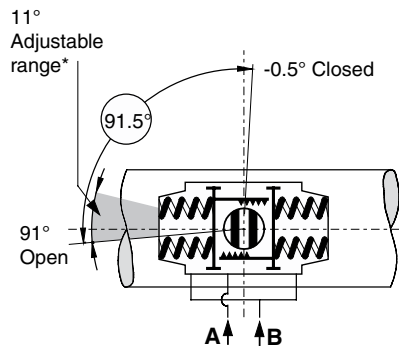

* only standard on E-Series actuators

ACTUATOR TYPE		E12	E25	E40	E65	E100	E150	E200	E350	E600	E950	E1600	P2500	P4000	
Bore	mm.	46	56	70	80	91	103	110	145	175	200	230	300	325	
Stroke	mm.	12.6	15.7	18.8	22	25.1	31.4	37.7	37.7	44	50.3	62.8	56.5	81.7	
Weight:	Double acting	kg.	0.6	1.3	1.8	2.4	3.1	4.8	5.8	10.4	19.4	26.4	42.7	56.8	86.6
	Spring return	kg.	0.7	1.7	2.4	3.6	4.6	6.9	9.1	16.9	27.6	38.6	65.8	88.2	131.8
Operating time	sec.	0.4	0.5	0.7	1.1	1.2	1.8	2.3	3.6	4.5	5.4	6.9	7	12	
Air consumption at 1 atm (litres)	port A	stroke	0.1	0.1	0.2	0.3	0.4	0.73	0.8	1.8	2.9	4.7	7.3	8	13.5
	port B	stroke	0.1	0.1	0.2	0.4	0.5	0.65	1	1.9	3.1	4.9	8.0	9.3	17.5

EL-O-MATIC

www.El-O-matic.com

Copyright © Emerson Process Management. The information in this document is subject to change without notice.

Updated data sheets can be obtained from our website www.El-O-Matic.com or from your nearest Valve Automation Center **USA:** +1 813 319 0266 **Europe:** +31 74 256 10 10 **Asia-Pacific:** +65 6501 4600



EMERSON
Process Management

Data sheet

Sheet No.: 1.501.01 Rev. B
Date: January 2012

EL-O-MATIC ACTUATOR WITH ONE WAY LIMIT STOPS

L1/LF

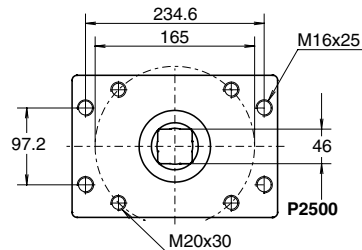
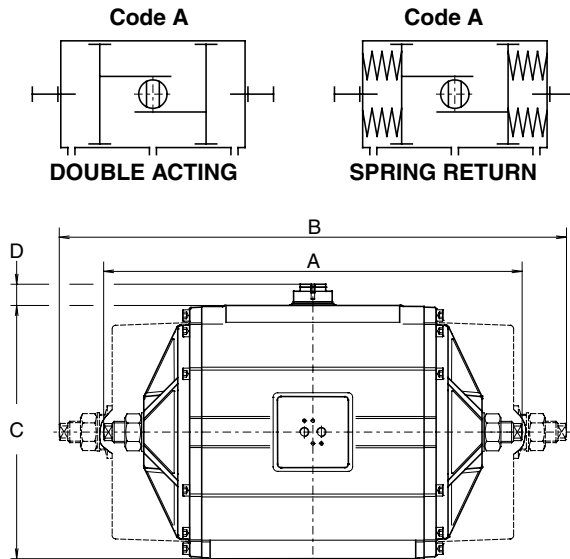

Note: Do not adjust under pressure.

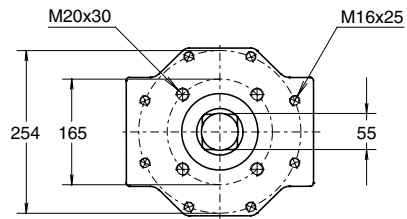

Dim. in mm.	ACTUATOR TYPE	
	P2500	P4000
A	580	708
B	795	1152
C	356	380
D	30	30

Description

Actuators with one way adjustable limit stops are used where the maximum opening (or closing) position of the valve needs to be reduced. For instance to adjust the maximum capacity of a remote operated valve. Also actuators with 180° rotation are available with these stops.

Operation

Stop screws are fitted to both endcaps and the screw length is such that adjustment is possible through the specified rotation of the actuator. The modified endcap is machined for -0.5° to +93° rotation for all P-Series models.

Identification

"L1" is added to the basic part number i.e. PD2500-L1

Specification

Pressure : Up to 8 bar
 Operating media : Air, dry or lubricated or non-corrosive gas
 Torque (90°) : Data sheet 1.104.01 - 1.104.04
 (180°) : Data sheet P-Series 1.204.01 and 1.204.02
 Other dimensions : Data sheet 1.103.XXX (90°)
 : Data sheet 1.203.011 (180°)
 Temperature: -20° to +80°C
 Adjustable range : 80°-93°(90°) or 160°-186° (180°)

Adjustable position (see data sheet 1.503 or 1.504):

Code	Position	Spring to:
A	Valve open	close
B	Valve open	close
C	Valve closed	open
D	Valve closed	open

Note:

- 1) Can be provided with extra long screws for full range adjustment (identification: PD2500-LF)
- 2) This option in combination of a manual override gearbox is redundant

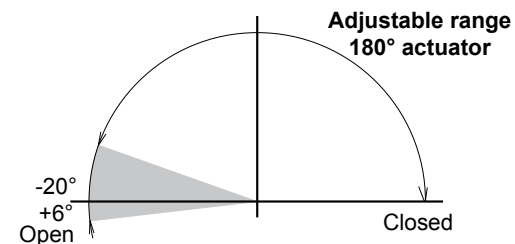
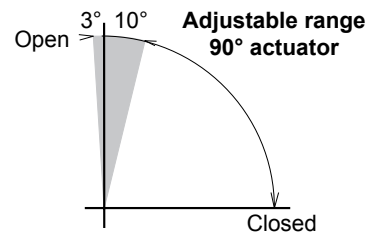

EL-O-MATIC

www.El-O-matic.com

Copyright © Emerson Process Management. The information in this document is subject to change without notice.

Updated data sheets can be obtained from our website www.El-O-matic.com or from your nearest Valve Automation Center **USA:** +1 813 319 0266 **Europe:** +31 74 256 10 10 **Asia-Pacific:** +65 6501 4600



EMERSON
Process Management

Data sheet

Sheet No.: 1.501.03 Rev. A
Date: November 2009

LIMIT STOP PLATE DIMENSIONS

LS 420

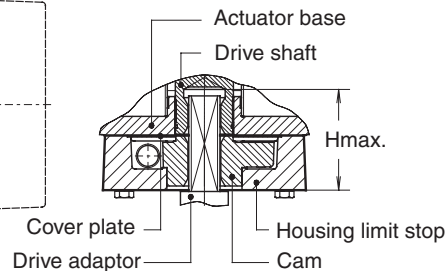
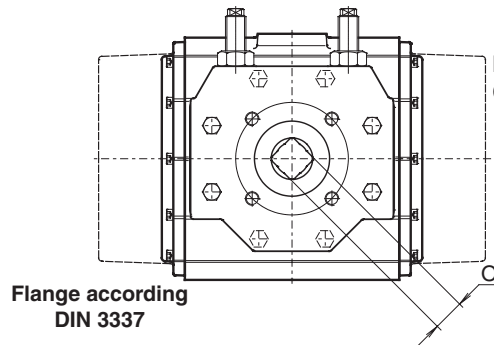
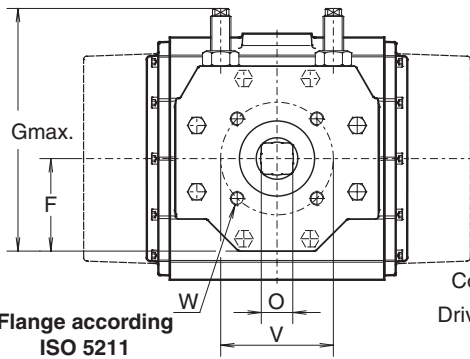
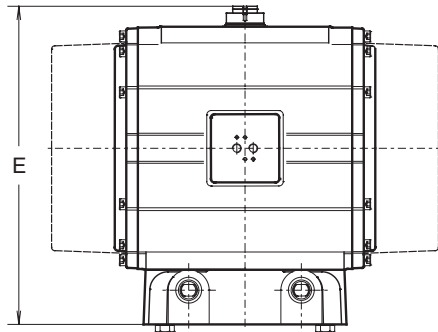

Note:
Cover plate only in combination with P2500

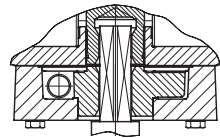

Description

These limit stop plates are used when precise control is required for both end of stroke positions. It is possible to adjust 15° of both ends of the standard stroke.

Construction

The complete stop plate assembly may be added to the 90° P- series actuators. The assembly is normally sandwiched between the actuator and mounting surface of the valve or bracket. Bearing rings are used at both surfaces to provide a long life expectancy.

The unit is assembled with a drive adaptor which passes through the stop plate, into the square actuator and provides the coupling between the two components. This drive adaptor normally also accommodates the coupling of the valve stem.

Identification

"LS420" is added to the basic part number i.e. PD2500-LS420

Other dimensions

See data sheet 1.103.xxx

Option

Version for 180° or DIN-standard actuator

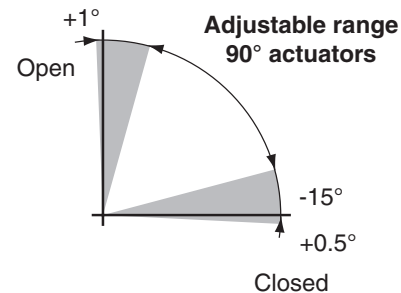

Dim. in mm.	ACTUATOR TYPE	
	P2500	P4000
E	466	490
F	135	135
G	322	322
H	130	141
O	46	55
V	165	165
W	M20x30	M20x30



www.El-O-matic.com

Copyright © Emerson Process Management. The information in this document is subject to change without notice.

Updated data sheets can be obtained from our website www.El-O-matic.com or from your nearest Valve Automation Center **USA:** +1 813 319 0266 **Europe:** +31 74 256 10 10 **Asia-Pacific:** +65 6501 4600



EMERSON
Process Management

Data sheet

Sheet No.: 1.501.05 Rev. A

Date: November 2009

EL-O-MATIC ACTUATOR WITH DOUBLE STROKE ADJUSTMENT

DSA

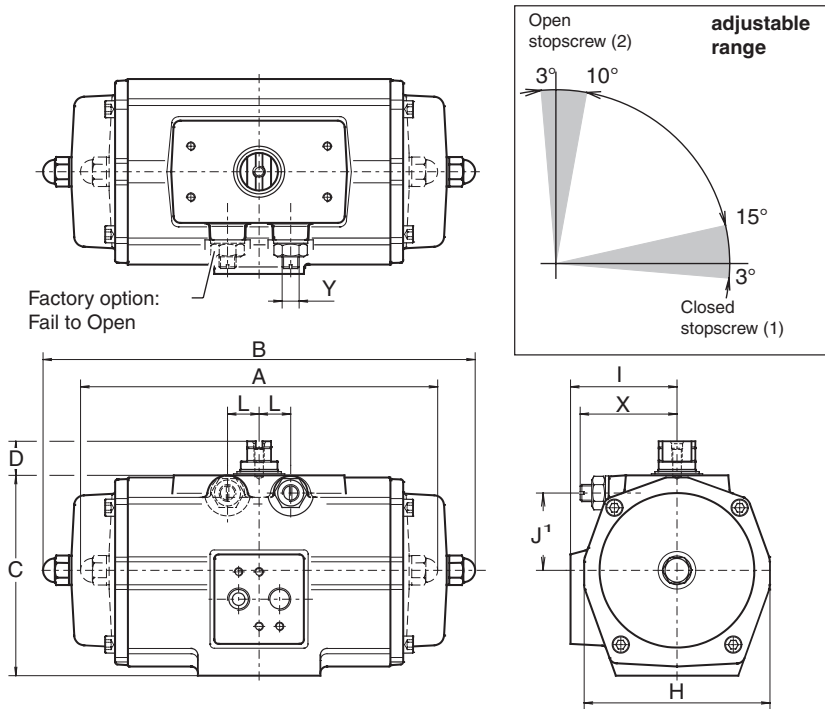

Description

Actuators with double stroke adjustment are normally used for high performance butterfly valves where a fine adjustment is required for the closed position. In this version adjustment is provided at the end of the opening and closing stroke positions. DSA actuators may be double acting or spring return, though are normally used as spring return (fail close) actuators.

Operation

The closed position is adjusted by means of the stop-screw (1) located in the actuator body and for the open position by the stop-screws (2) in the actuator end caps.

Identification

See data sheet A 1.102.10.

Specification

Pressure : Up to 8 bar
 Operating media : Air, dry or lubricated or non-corrosive gas
 Torque (90°) : Data sheet 1.104.01 - 1.104.02
 Rotation -
 Spring return : Clock-wise on air failure.
 Double acting : Counter clock-wise with port "A" pressurised.
 Other dimensions : Data sheet 1.103.XXX
 Temperature : -20° to +80°C
 Adjustable range : Closed position (1), +3°- 15°
 Open position (2), 80° - 93°

Note

- 1) Can be provided with extra long end-cap stop screws for full range adjustment of the "open" position.
- 2) This DSA option is not required on actuators fitted with manual override gearboxes, as MO gearboxes already incorporate this function.

Important

- 1) "Fail open" is factory option.
- 2) When assembled for "fail open" operation (code D; see data sheet 1.504), both stop-screws (1) and (2) will adjust the closed position. There is no adjustment for the open position!

Dim.	Actuator type									
	E25	E40	E65	E100	E150	E200	E350	E600	E950	E1600
A DA	159	180	199	221	254	283	305	390	440	520
B SR	172	204	249	267	310	360	387	480	532	641
C	80	93	105	118	140	143	181	220	259	297
D	20	20	20	20	20	20	20	30	30	30
H	74	86	98	108	121	128	173	207	231	264
I	46	51	57.5	63	70	73	94.3	113	126	142
J1	28.3	35.1	40	43.7	48.7	53.9	72.5	88.8	102.4	114.4
L	11.5	15.5	15.5	18.5	24.6	24.6	24.6	41.5	41.5	47.5
Y	M6	M8	M8	M10	M10	M12	M12	M16	M16	M20
X	36	41.5	41.5	50.5	60	62.5	72.5	102	102	109.5
X max.	41.5	48.5	48.5	58.5	67	74	84	114.5	114.5	124

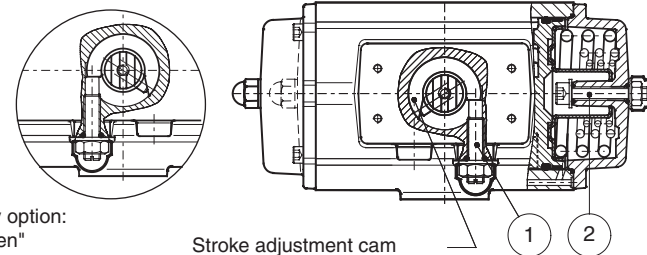

Factory option:
"Fail open"

Stroke adjustment cam

EL-O-MATIC™

www.El-O-matic.com

Copyright © Emerson Process Management. The information in this document is subject to change without notice.

Updated data sheets can be obtained from our website www.El-O-matic.com or from your nearest Valve Automation Center **USA:** +1 813 319 0266 **Europe:** +31 74 256 10 10 **Asia-Pacific:** +65 6501 4600

EMERSON™
Process Management

Data sheet

Sheet No.: 1.103.073 Rev. B

Date: June 2010

DIMENSION SHEET STANDARD ACTUATOR - DIN

E/P

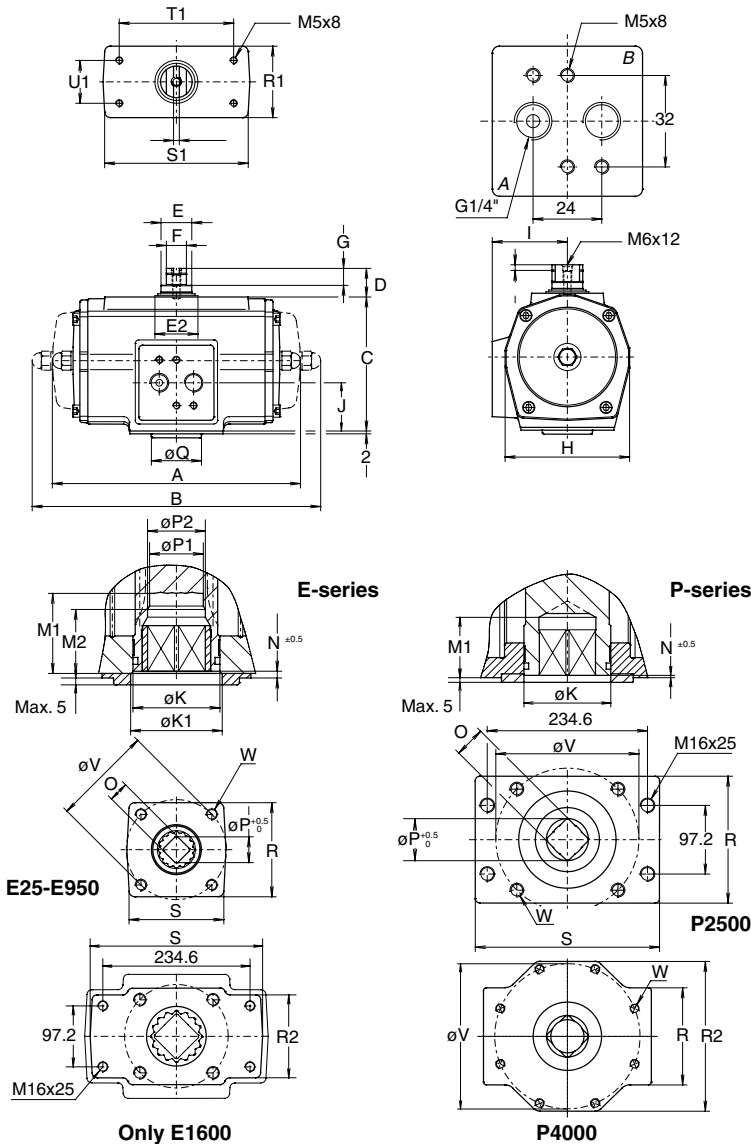

Dim. in mm.	Actuators E-series										P-series	
	E 12	E 25	E 40	E 65	E100	E150	E200	E 350	E600	E950	E1600	P2500
A DA	159	180	199	221	254	283	305	387	424	516	378	502
B SR	172	204	249	267	310	360	387	477	517	637	570	834
C	80	93	105	118	140	143	181	220	259	297	356	380
D	20	20	20	20	20	20	20	30	30	30	30	30
E	16	22	22	22	36	36	36	55	55	64	55	64
E2	23	30	30	30	45	45	45	65	65	75	65	80
F	10	14	14	14	19	19	19	36	36	36	36	36
G	12	12	12	12	12	12	12	10	10	10	10	10
H	74	86	98	108	121	128	173	207	231	265	350	380
I	46	53	58	63	70	73	95	113	126	142	183	200
J	32	34	40	45	59	51	73	84.5	105.5	120.5	178	190
K	24	33	33	38	55	55	55	68	75	95	85	120
K1	29	32	32	40	50	54	54	68	75	95	-	-
M1	34.5	34.5	34.5	34.5	50	50	50	52	64	82	66	77
M2	-	-	-	27	-	37	37	-	-	-	-	-
N	3	3	3	3.5	3.5	3.5	3.5	3.5	3.5	3.5	3	1.5
O max.	11.08	14.08	14.08	17.08	17.08	22.10	22.10	27.11	36.16	46.16	46.21	55.24
O min.	11.00	14.00	14.00	17.00	17.00	22.00	22.00	27.00	36.00	46.00	46.05	55.05
P	14.1	18.1	18.1	22.2	22.5	28.2	36.2	36.2	48.2	60.2	60.2	72.2
P1	14.1	18.1	21.1	23.1	28.5	32.1	32.1	36.5	48.5	60.5	-	-
P2	-	-	-	25.2	-	36.2	36.2	-	-	-	-	-
Q	35	35	35	55	55	70	70	85	100	130	130	200
R	52	65	70	70	86	90	114	124	130	154	170	170
R1	50	50	50	60	60	60	60	90	90	125	160	160
R2	-	-	-	-	-	-	-	-	-	132	-	262
S	52	65	70	70	92	90	114	124	142	280	290	290
S1	100	100	100	100	100	100	100	170	170	210	245	245
T1	80	80	80	80	80	80	80	130	130	130	130	130
U1	30	30	30	30	30	30	30	30	30	30	30	30
	F05	F05	F05	F07	F07	F10	F10	F12	F14	F16	F16	F25
V	50	50	50	70	70	102	102	125	140	165	165	254
W	M10 x 16	M10 x 16	M10 x 16	M8 x 13	M8 x 13	M10 x 16	M10 x 16	M12 x 20	M16 x 25	M20 x 30	M20 x 30	M16 x 25
Optional dimensions												
K1'	-	40	40	32	54	50	50	-	-	-	-	-
Q'	-	55	55	35	70	55	55	-	-	-	-	-
	F03	F07	F07	F05	F10	F07	F07	F10	F10	-	-	-
V'	36	70	70	50	102	70	70	102	102	-	-	-
W'	M5 x 8	M8 x 13	M8 x 13	M6 x 10	M10x16	M8 x 13	M8 x 13	M10x 16	M10 x 16	-	-	-

For E12 dimensions see data sheet 1.103.103

Note

1. Flange and square drive to DIN 3337
2. Top and solenoid flange to VDI/VDE 3845 (NAMUR)
3. For P-series actuators with limit stops see 1.501.01



www.El-O-matic.com

Copyright © Emerson Process Management. The information in this document is subject to change without notice.

Updated data sheets can be obtained from our website www.El-O-matic.com or from your nearest Valve Automation Center **USA:** +1 813 319 0266 **Europe:** +31 74 256 10 10 **Asia-Pacific:** +65 6501 4600



EMERSON
Process Management

Data sheet

Sheet No.: 1.103.106 Rev. A

Date: November 2009

DIMENSION SHEET STANDARD ACTUATOR - ISO

E/P

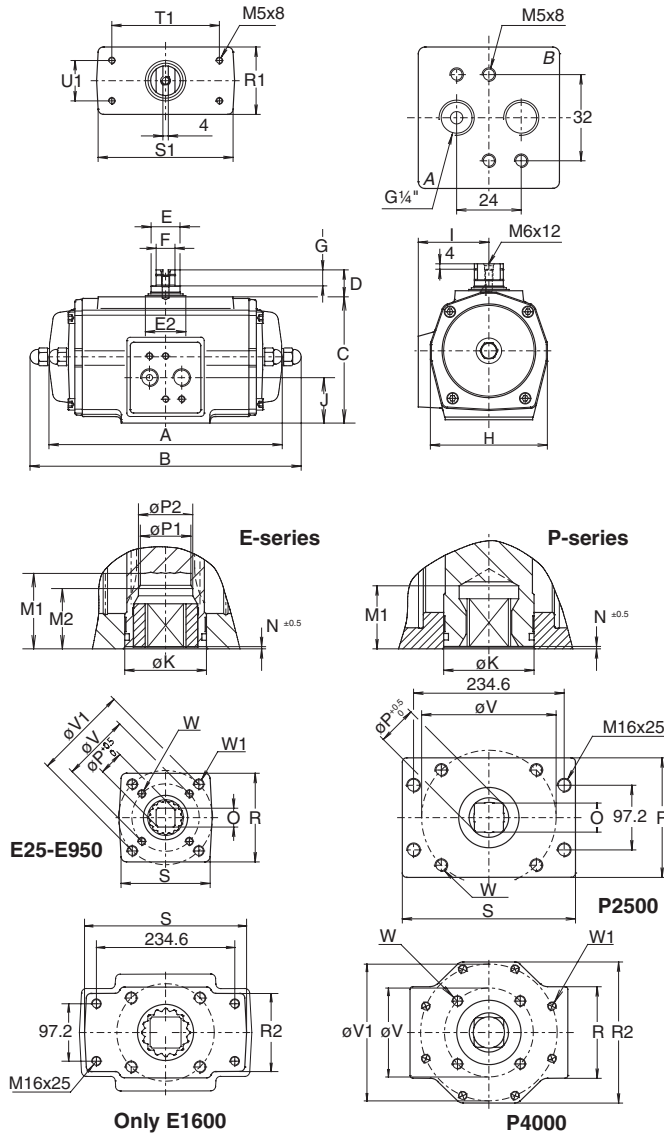

Dim. in mm.	Actuators E-series										P-series	
	E 12	E 25	E 40	E 65	E100	E150	E200	E 350	E600	E950	E1600	P2500
A DA	159	180	199	221	254	283	305	387	424	516	378	502
B SR	172	204	249	267	310	360	387	477	517	637	570	834
C	80	93	105	118	140	143	181	220	259	297	356	380
D	20	20	20	20	20	20	20	30	30	30	30	30
E	16	22	22	22	36	36	36	55	55	64	55	64
E2	23	30	30	30	45	45	45	65	65	75	65	80
F	10	14	14	14	19	19	19	36	36	36	36	36
G	12	12	12	12	12	12	12	10	10	10	10	10
H	74	86	98	108	121	128	173	207	231	265	350	380
I	46	53	58	63	70	73	95	113	126	142	183	200
J	32	34	40	45	59	51	73	84.5	105.5	120.5	178	190
K	24	33	33	38	55	55	55	68	75	95	85	120
M1	34.5	34.5	34.5	34.5	50	50	50	52	64	82	66	77
M2	-	-	-	27	-	37	-	-	-	-	-	-
N	1	1	1	1.5	1	1.5	1.5	1.5	1.5	1.5	3	1.5
O max.	11.08	14.08	14.08	19.08	19.08	22.10	27.11	27.11	36.16	46.16	46.21	55.24
O min.	11.00	14.00	14.00	19.00	19.00	22.00	27.00	27.00	36.00	46.00	46.00	55.00
P	14.1	18.1	18.1	25.2	25.5	28.2	36.2	36.2	48.2	60.2	60.2	72.2
P1	14.1	18.1	21.1	23.1	28.5	32.1	32.1	36.5	48.5	60.5	-	-
P2	-	-	-	25.2	-	36.2	36.2	-	-	-	-	-
R	52	65	70	70	86	90	114	124	130	154	170	170
R1	50	50	50	60	60	60	60	90	90	125	160	160
R2	-	-	-	-	-	-	-	-	-	132	-	262
S	52	65	70	70	92	90	114	124	142	280	290	290
S1	100	100	100	100	100	100	100	170	170	210	245	245
T	-	-	-	-	-	-	-	-	-	234.6	234.6	-
T1	80	80	80	80	80	80	80	130	130	130	130	130
U	-	-	-	-	-	-	-	-	-	97.2	97.2	-
U1	30	30	30	30	30	30	30	30	30	30	30	30
V	36	50	50	50	70	70	70	102	102	165	165	165
W	M5 x 8	M6 x 10	M6 x 10	M6 x 10	M8 x 13	M8 x 13	M8 x 13	M10 x 16	M10 x 16	M20 x 30	M20 x 30	M20 x 30
V1	50	70	70	70	102	102	102	125	140	-	-	254
W1	M6 x 10	M8 x 13	M8 x 13	M8 x 13	M10 x 16	M10 x 16	M10 x 16	M12 x 20	M16 x 25	-	-	M16 x 25

Note

1. Flange and square drive to ISO 5211
2. Top and solenoid flange to VDI/VDE 3845 (NAMUR)
3. For P-series actuators with limit stops see 1.501.01

EL-O-MATIC

www.El-O-matic.com

Copyright © Emerson Process Management. The information in this document is subject to change without notice.

Updated data sheets can be obtained from our website www.El-O-matic.com or from your nearest Valve Automation Center **USA:** +1 813 319 0266 **Europe:** +31 74 256 10 10 **Asia-Pacific:** +65 6501 4600



EMERSON
Process Management

Data sheet

Sheet No.: 1.103.102 Rev. A

Date: November 2009

DIMENSION SHEET ACTUATOR ISO E12 (90°/180°)

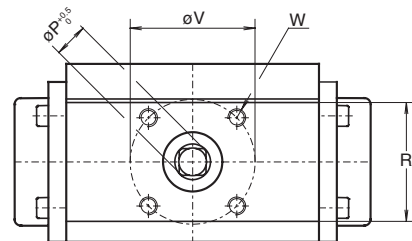
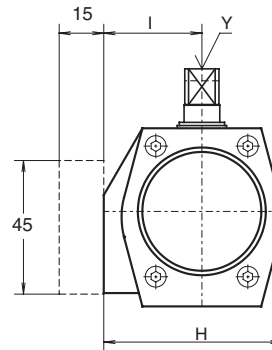
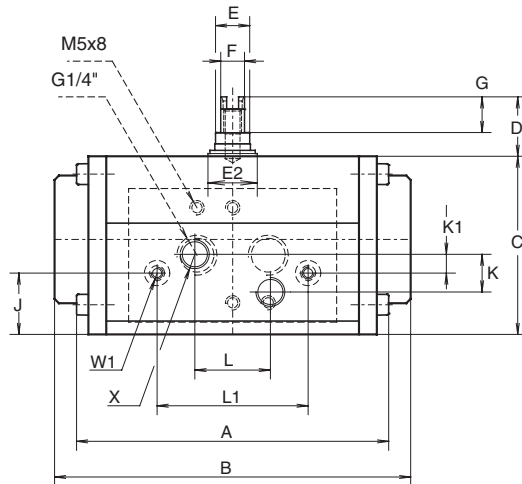
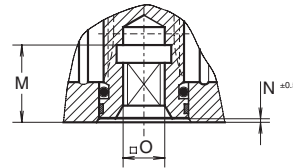
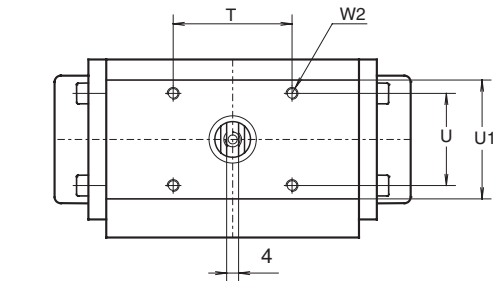

Dim. in mm	90°	180°
A ED	103	155
B ES	118	216
C	60	60
D	20	20
E	16	16
E2	23	23
F	10	10
G	12	12
H	60	60
I	33	33
J	21	21
K	12.7	12.7
K1	6.4	6.4
L	25.4	25.4
L1	50.8	50.8
M	16.5	16.5
N	1	1
O max.	9.1	9.1
O min.	9	9
P	12.1	12.1
R	40	40
R1	40	40
T	40	40
U	31	31
V	42	42
W	M6x8	M6x8
W1	M4x7	M4x7
W2	M4x7	M4x7
X	G1/8"	G1/8"
Y	M6x12	M6x12

DOUBLE ACTING TORQUE (ED)

Pressure	bar	3.5	4	4.5	5	5.5	6	7
Torque 90°/180°	Nm	8.5	9.7	10.9	12.2	13.4	14.6	17.1

SINGLE ACTING TORQUE (ES)

	bar	Air stroke				Spring stroke	
		5		6		start	end
Pressure	-	start	end	start	end		
Position	-					start	end
Torque 90°	Nm	7.6	4.9	10	7.5	7.2	4.6
Torque 180°	Nm	7.8	5	10.4	7.6	7.1	4.5

Note: Dotted image represents optional NAMUR solenoid interface block

EL-O-MATIC™

www.El-O-matic.com

Copyright © Emerson Process Management. The information in this document is subject to change without notice.

Updated data sheets can be obtained from our website www.El-O-matic.com or from your nearest Valve Automation Center **USA:** +1 813 319 0266 **Europe:** +31 74 256 10 10 **Asia-Pacific:** +65 6501 4600



EMERSON™
Process Management

Data sheet

Sheet No.: 1.103.103 Rev. A

Date: November 2009

DIMENSION SHEET ACTUATOR DIN E12 (90°/180°)

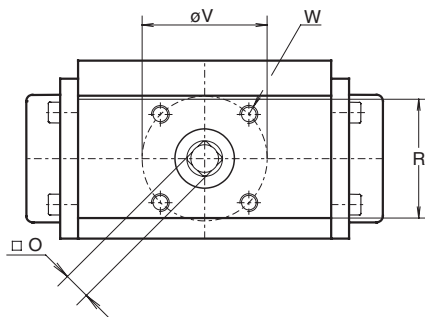
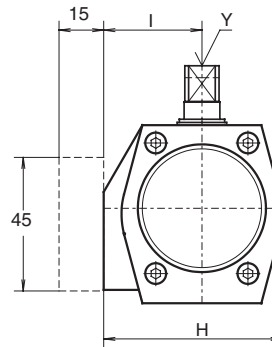
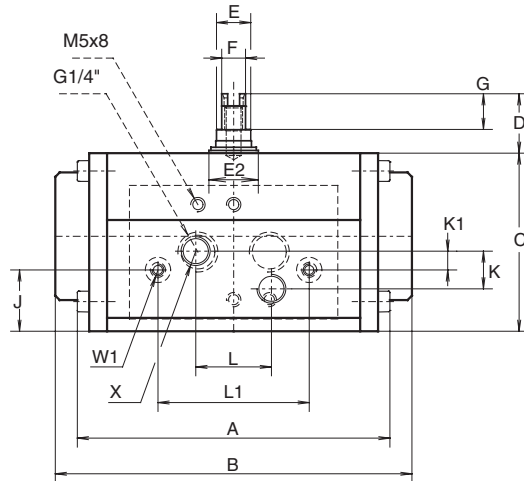
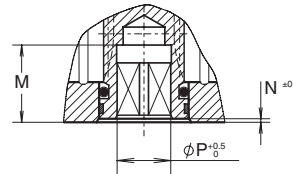
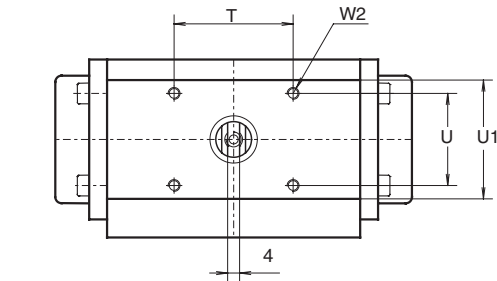

Dim. in mm	90°	180°
A ED	103	155
B ES	118	216
C	60	60
D	20	20
E	16	16
E2	23	23
F	10	10
G	12	12
H	60	60
I	33	33
J	21	21
K	12.7	12.7
K1	6.4	6.4
L	25.4	25.4
L1	50.8	50.8
M	16.5	16.5
N	1	1
O max.	9.1	9.1
O min.	9	9
P	12.1	12.1
R	40	40
R1	40	40
T	40	40
U	31	31
V	42	42
W	M6x8	M6x8
W1	M4x7	M4x7
W2	M4x7	M4x7
X	G1/8"	G1/8"
Y	M6x12	M6x12

DOUBLE ACTING TORQUE (ED)

Pressure	bar	3.5	4	4.5	5	5.5	6	7
Torque 90°/180°	Nm	8.5	9.7	10.9	12.2	13.4	14.6	17.1

SINGLE ACTING TORQUE (ES)

Pressure	bar	Air stroke				Spring stroke	
		5		6		start	end
Position	-	start	end	start	end		
Torque 90°	Nm	7.6	4.9	10	7.5	7.2	4.6
Torque 180°	Nm	7.8	5	10.4	7.6	7.1	4.5

Note: Dotted image represents optional NAMUR solenoid interface block

EL-O-MATIC™

www.El-O-matic.com

Copyright © Emerson Process Management. The information in this document is subject to change without notice.

Updated data sheets can be obtained from our website www.El-O-matic.com or from your nearest Valve Automation Center **USA:** +1 813 319 0266 **Europe:** +31 74 256 10 10 **Asia-Pacific:** +65 6501 4600



EMERSON™
Process Management

Data sheet

Sheet No.: 1.103.200 Rev. B
Date: January 2012

DRIVE INSERTS FOR EL-O-MATIC ACTUATORS

E

Standard available insert shapes

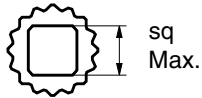

Optional available insert shapes

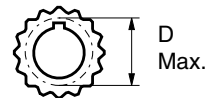
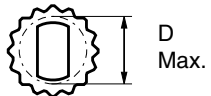

Insert mounting acc. ISO 5211

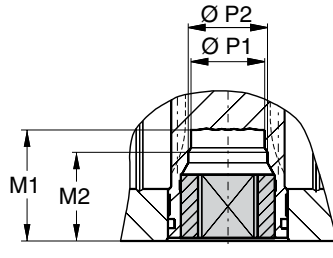

Insert mounting acc. DIN 3337

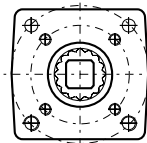
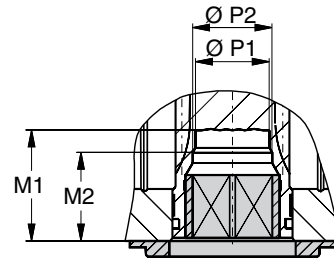

Centering plate

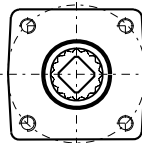

Description

Most of the EI-O-Matic actuators are fitted with drive inserts. This enables actuators to be directly mounted onto suitable valves and eliminates the need for a bracket and coupling type mounting kit. The use of direct mounts significantly cuts the cost of the valve/actuator assembly.

Standard actuators are fitted with square drive inserts in accordance with ISO 5211 (or DIN 3337), but a wide variety of other inserts are also available. Special inserts may have oversize or undersize squares, double-D and shaft key way forms.

Drive inserts can be supplied on factory built actuators or as loose items and are easily replaceable at distributor or end user level.

Where direct mounts are not possible, for instance on valves with exposed grand packing, the use of inserts often simplifies the design of the mounting kit.

Material : Aluminium alloy
Finish : Anodised

The following actuator types do not have inserts.

- E12,
- P2500 and P4000
- 180° actuators

These actuators have inner square directly in the bottom of the pinion.
See the following data sheets for more information :

E12 ISO5211 1.103.102
 DIN 3337 1.103.103

P2500/P4000 DIN 3337 1.103.073
 ISO 5211 1.103.106

180° DIN 3337 1.203.011
 ISO 5211 1.203.021

Dim. in mm	Inserts with inner-square-dimensions per actuator type								
	E25	E40 / E65	E100	E150	E200	E350	E600	E950	E1600
Standard inserts dimensions									
ISO5211	11	14	19	19	22	27	27	36	46
DIN3337	11	14	17	17	22	22	27	36	46
Optional insert dimensions									
	9	10	12	14	14	14	14	22	-
	10	12	14	16	16	16	16	-	-
	-	-	16	22	17	17	17	-	-
	-	-	-	24	19	19	19	-	-
	-	-	-	27	24	24	24	-	-
Maximum insert dimensions									
M1	34.5	34.5	34.5	50	50	50	52	64	82
M2	-	-	27	-	37	37	-	-	-
P1	14.1	18.1	23.1	28.5	32.1	32.1	36.5	48.5	60.5
P2	-	-	25.2	-	36.2	36.2	-	-	-
Sq max.	11	16	19	27	27	27	27	36	46
D max.	13.8	21	23.6	33.6	33.6	33.6	33.6	45	60

EL-O-MATIC™

www.El-O-matic.com

Copyright © Emerson Process Management. The information in this document is subject to change without notice.

Updated data sheets can be obtained from our website www.El-O-matic.com or from your nearest Valve Automation Center **USA:** +1 813 319 0266 **Europe:** +31 74 256 10 10 **Asia-Pacific:** +65 6501 4600



EMERSON™
Process Management

Data sheet

Sheet No.: 1.104.01 Rev. A
Date: November 2009

DOUBLE ACTING ACTUATOR TORQUE (Nm.)

90°

DOUBLE ACTING TORQUE

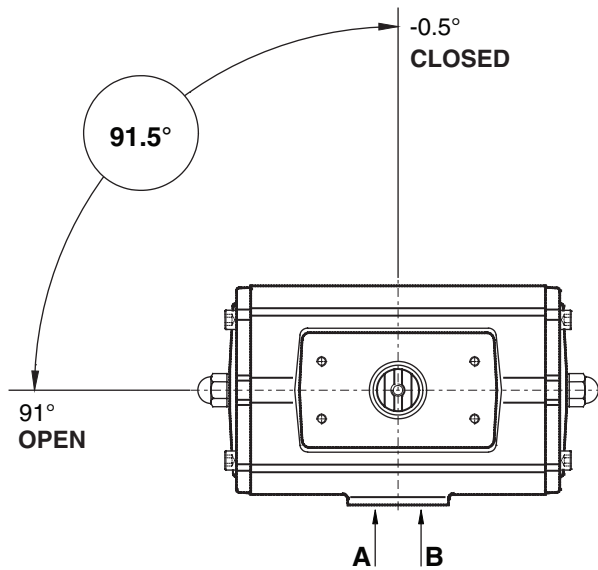
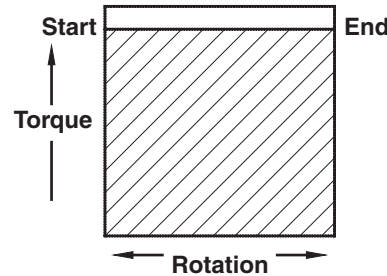

Actuator	Type	Size	Torque in Nm Supply Pressure (bar)									
			2	3	3.5	4	4.5	5	5.5	6	6.5	7
ED	12	4.8	7.3	8.5	9.7	11.0	12.2	13.4	14.6	15.9	17.1	19.6
ED	25	9	13	16	18	20	23	25	27	29	32	36
ED	40	17	25	29	34	38	42	47	51	55	59	68
ED	65	25	38	45	51	58	64	71	77	84	90	104
ED	100	38	57	66	76	86	95	105	115	124	134	153
ED	150	60	91	106	122	137	153	168	183	199	214	245
ED	200	82	124	146	167	188	209	230	251	272	293	335
ED	350	143	216	253	290	326	363	400	436	473	510	583
ED	600	243	368	430	492	554	617	679	741	804	866	991
ED	950	363	549	642	735	828	921	1014	1107	1200	1293	1479
ED	1600	600	907	1061	1214	1368	1522	1676	1829	1983	2137	2444
PD	2500	958	1449	1694	1940	2186	2431	2677	2922	3168	3413	3904
PD	4000	1623	2456	2872	3289	3705	4121	4537	4954	5370	5786	6619

Note

- Emerson Process Management recommends that the valve manufacturer supply the maximum required torque values (Including any adjustments or suggested safety factors for valve service conditions or application).
Additionally, the valve manufacturer must identify at which position(s) and direction(s) of rotation (Counter Clock Wise or Clock Wise) these maximum requirements occur.
- If in doubt, or you require any assistance with sizing actuators, do not hesitate to contact your nearest Emerson's Valve Automation Division representative.
- Pressure on port "A" opens the actuator*
- The actuator is shown in closed position*

(* code A, data sheet 1.503)



www.El-O-matic.com

Copyright © Emerson Process Management. The information in this document is subject to change without notice.

Updated data sheets can be obtained from our website www.El-O-matic.com or from your nearest Valve Automation Center **USA:** +1 813 319 0266 **Europe:** +31 74 256 10 10 **Asia-Pacific:** +65 6501 4600



EMERSON
Process Management

Data sheet

Sheet No.: 1.104.02 Rev. A

Date: November 2009

SPRING RETURN ACTUATOR TORQUE (Nm.)

90°

SINGLE ACTING TORQUE

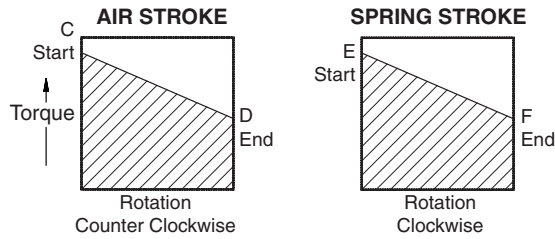

Note

- Emerson Process Management recommends that the valve manufacturer supply the maximum required torque values (Including any adjustments or suggested safety factors for valve service conditions or application). Additionally, the valve manufacturer must identify at which position(s) and direction(s) of rotation (Counter Clock Wise or Clock Wise) these maximum requirements occur.
- If in doubt, or you require any assistance with sizing actuators, do not hesitate to contact your nearest Emerson's Valve Automation Division representative.
- Pressure on port "A" opens the actuator*
- The actuator is shown in closed position* (* code A, data sheet 1.504)

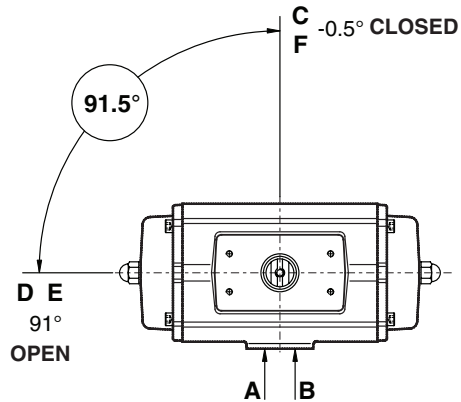

Springset nr.	Air Stroke (Nm)														Spring Stroke (Nm)				
	SUPPLY PRESSURE														E	F			
	3.0 barg		3.5 barg		4.0 barg		4.5 barg		5.0 barg		6.0 barg		7.0 barg						
Act. Type	C	D	C	D	C	D	C	D	C	D	C	D	C	D					
PS 2500	6	896	602	1142	848	1387	1093	1633	1339	1879	1585	2124	1830	2370	2076	2861	2567	792	497
	8	712	320	958	566	1203	811	1449	1057	1694	1302	1940	1548	2186	1794	2677	2285	1056	663
	10	-	-	774	284	1019	529	1265	775	1510	1020	1756	1266	2001	1511	2492	2002	1321	829
	12	-	-	-	-	835	247	1081	492	1326	738	1572	984	1817	1229	2308	1720	1585	995
	14	-	-	-	-	-	-	-	-	1142	456	1387	701	1633	947	2124	1438	1849	1160
PS 4000	6	1524	1028	1940	1444	2356	1860	2772	2276	3189	2693	3605	3109	4021	3525	4854	4358	1337	839
	8	1213	551	1629	968	2045	1384	2462	1800	2878	2216	3294	2633	3710	3049	4543	3882	1783	1119
	10	-	-	1318	491	1734	908	2151	1324	2567	1740	2983	2157	3400	2573	4232	3405	2229	1399
	12	-	-	-	-	1424	431	1840	848	2256	1264	2672	1680	3089	2097	3921	2929	2674	1679
	14	-	-	-	-	-	-	-	-	1945	788	2362	1204	2778	1620	3610	2453	3120	1958

Springset nr.	Air Stroke (Nm)														Spring Stroke (Nm)					
	SUPPLY PRESSURE														E	F				
	3.0 barg		3.5 barg		4.0 barg		4.5 barg		5.0 barg		6.0 barg		7.0 barg							
Act. Type	C	D	C	D	C	D	C	D	C	D	C	D	C	D						
ES 12	2	-	-	3.8	1.0	5.1	2.3	6.4	3.6	7.7	4.9	9.0	6.2	10.3	7.5	12.9	10.1	7.2	4.6	
	ES 25	2	9	6	12	9	14	11	16	13	19	16	21	18	24	21	29	25	7	4
	3	7	2	9	5	12	7	14	9	16	12	19	14	21	17	26	21	11	7	
	4	-	-	-	-	9	3	11	5	14	8	16	10	19	13	23	17	14	9	
	5	-	-	-	-	-	-	-	-	11	4	14	6	16	8	21	13	18	11	
ES 40	2	-	-	-	-	-	-	-	-	-	-	-	-	14	4	18	9	21	13	
	ES 65	2	17	12	22	16	26	21	31	25	35	30	40	34	44	39	53	48	13	8
	3	12	4	17	8	22	13	26	18	31	22	35	27	40	31	49	40	20	12	
	4	-	-	-	-	17	5	21	10	26	14	30	19	35	23	44	33	26	17	
	5	-	-	-	-	-	-	-	-	21	7	26	11	30	16	39	25	33	21	
ES 100	2	-	-	-	-	-	-	-	-	-	-	-	-	25	8	34	17	40	25	
	ES 150	2	26	17	32	23	39	30	46	37	53	44	60	51	67	58	81	72	21	13
	3	18	5	25	11	32	18	39	25	46	32	52	39	59	46	73	60	32	20	
	4	-	-	-	-	24	6	31	13	38	20	45	27	52	34	66	48	42	26	
	5	-	-	-	-	-	-	-	-	30	8	37	15	44	22	58	36	53	33	
ES 200	2	-	-	-	-	-	-	-	-	-	-	-	-	37	10	50	23	63	40	
	ES 350	2	39	27	49	37	60	47	70	57	80	67	90	78	100	88	121	108	29	18
	3	29	10	39	20	49	30	59	41	70	51	80	61	90	71	110	92	44	27	
	4	-	-	-	-	39	14	49	24	59	34	69	44	80	54	100	75	58	37	
	5	-	-	-	-	-	-	-	-	49	17	59	27	69	38	89	58	73	46	
ES 600	2	-	-	-	-	-	-	-	-	-	-	-	-	59	21	79	41	88	55	
	ES 950	2	63	41	79	58	95	74	112	90	128	107	144	123	161	139	193	172	48	29
	3	46	14	62	30	79	47	95	63	111	79	128	96	144	112	177	145	72	44	
	4	-	-	-	-	62	19	78	36	95	52	111	68	127	85	160	117	95	58	
	5	-	-	-	-	-	-	-	-	78	24	94	41	110	57	143	90	119	73	
ES 1600	2	-	-	-	-	-	-	-	-	-	-	-	-	94	30	126	62	143	88	
	ES 2500	2	85	57	107	79	130	101	152	124	174	146	197	169	219	191	264	236	65	41
	3	62	19	84	42	106	64	129	86	151	109	173	131	196	153	240	198	98	61	
	4	-	-	-	-	83	26	105	49	127	71	150	93	172	116	217	160	131	82	
	5	-	-	-	-	-	-	-	-	104	33	126	56	149	78	193	123	164	102	
ES 2500	2	-	-	-	-	-	-	-	-	-	-	-	-	125	41	170	85	196	123	
	ES 350	2	144	96	183	135	221	174	260	213	299	252	338	290	377	329	454	407	116	74
	3	101	30	140	68	179	107	217	146	256	185	295	224	334	263	412	340	174	112	
	4	-	-	-	-	136	41	175	80	214	118	252	157	291	196	369	274	232	149	
	5	-	-	-	-	-	-	-	-	171	52	210	91	249	130	326	207	289	186	
ES 600	2	-	-	-	-	-	-	-	-	-	-	-	-	206	63	283	141	347	223	
	ES 950	2	249	166	315	232	381	298	447	364	513	430	579	496	645	562	777	694	195	122
	3	179	54	245	120	311	186	377	252	443	318	509	384	575	450	707	582	292	183	
	4	-	-	-	-	240	74	306	140	372	206	438	272	504	338	636	470	389	245	
	5	-	-	-	-	-	-	-	-	302	94	368	160	434	226	566	358	487	306	
ES 1600	2	-	-	-	-	-	-	-	-	-	-	-	-	364	114	496	246	584	367	
	ES 2500	2	375	249	474	347	572	446	671	544	769	643	868	741	966	840	1163	1037	290	179
	3	272	82	371	181	469	279	568	378	666	476	765	575	863	673	1060	870	434	269	
	4	-	-	-	-	366	113	465	211	563	310	662	408	760	507	957	704	579	359	
	5	-	-	-	-	-	-	-	-	460	143	559	242	657	340	854	537	724	448	
ES 2500	2	-	-	-	-	-	-	-	-	-	-	-	-	554	174	751	371	869	538	
	ES 600	2	617	416	780	579	943	742	1106	905	1269	1068	1432	1231	1594	1394	1920	1719	474	299
	3	445	144	608	307	771	470	934	633	1097	796	1260	959	1423	1121	1748	1447	711	449	
	4	-	-	-	-	599	198	762	361	925	523	1088	686	1251	849	1577	1175	947	598	
	5	-	-	-	-	-	-	-	-	753	251	916	414	1079	577	1405	903	1184	748	
6	-	-	-	-	-	-	-	-	-	-	-	-	907	305	1233	630	1421	897		



www.El-O-matic.com

Copyright © Emerson Process Management. The information in this document is subject to change without notice.

Updated data sheets can be obtained from our website www.El-O-matic.com or from your nearest Valve Automation Center **USA:** +1 813 319 0266 **Europe:** +31 74 256 10 10 **Asia-Pacific:** +65 6501 4600



EMERSON
Process Management

Data sheet

Sheet No.: 1.101.33 Rev. B

Date: January 2012

CONSTRUCTION, PARTS AND MATERIALS E-SERIES ACTUATORS

E

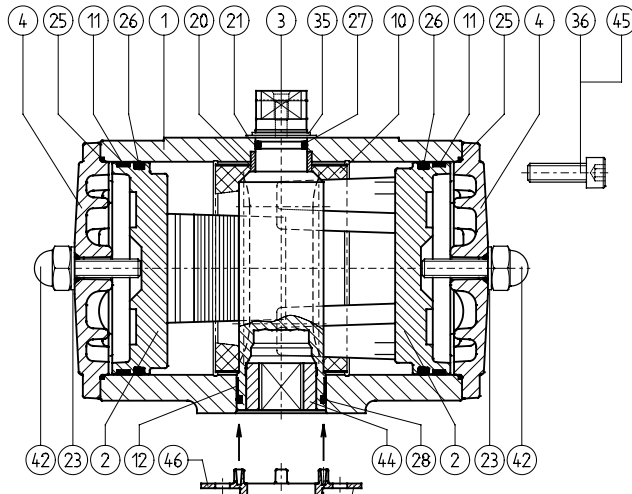

Optional centre-plate

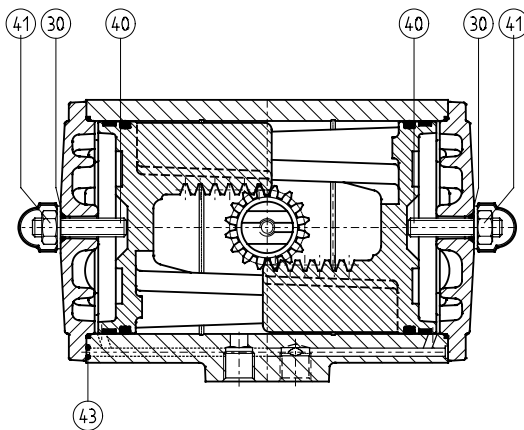

DOUBLE ACTING ED

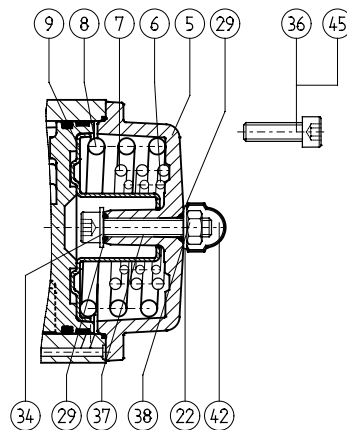

SINGLE ACTING ES

Notes

- 1 Hard anodised aluminium alloy: AlZnMgCu1.5, DIN 1725/1
- 2 Deltatone® Coating
- 3 Anodised
- 4 Zinc plated and passivated
- 5 CSR Coating (see 4.204.02)
- 6 Stainless Steel Sandvic 1802, SS2382
- 7 Stainless Steel X35CrM017
- 8 No insert, adaptor square direct in pinion

Parts			Materials		Executions		
Nr.	Description	Qty.	Description	Specification	Std	S.S. Shaft	CSR
1	Body	1	Aluminium Alloy	GAISi10Mg, DIN 1725/2	-	-	5
2	Piston	2	Aluminium Alloy	GAISi 7Mg, DIN 1725/2	-	-	-
3	Drive Shaft	1	Aluminium Alloy	AlZnMgCu1.5, DIN 1725/1	1	6	6
4	End Cap ED	2	Aluminium Alloy	GDAISi9Cu3, DIN 1725/2	-	-	5
5	End Cap ES	2	Aluminium Alloy	GDAISi9Cu3, DIN 1725/2	-	-	5
6	Spring- inner	2	Carbon Spring Steel	Class C, DIN17223	2	2	2
7	Spring- mid	2	Carbon Spring Steel	Class C, DIN17223	2	2	2
8	Spring- outer	2	Carbon Spring Steel	Class C, DIN17223	2	2	2
9	Spring Holder	2	Steel	RSt 14-03, DIN 1623	3	3	3
10	* Guide Band	1	Nylatron	PA6.6 + MoS2	-	-	-
11	* Guide Band	2	PTFE, Carbon filled	PTFE + 25% C	-	-	-
12	* Bearing Bush	1	Nylatron	PA6.6 + MoS2	-	-	-
20	* Bearing Bush	1	Delrin	POM	-	-	-
21	* O-ring	1	Nitrile Rubber	Buna N	-	-	-
22	* Washer ES	2	Nylon	PA6	-	-	-
23	* Washer ED	2	Nylon	PA6	-	-	-
25	* O-ring	2	Nitrile Rubber	Buna N	-	-	-
26	* O-ring	2	Nitrile Rubber	Buna N	-	-	-
27	* Washer	1	ZEDEX 100 K	-	-	-	-
28	* O-ring	1	Nitrile Rubber	Buna N	-	-	-
29	* O-ring	4	Nitrile Rubber	Buna N	-	-	-
30	* O-ring	2	Nitrile Rubber	Buna N	-	-	-
34	Washer ES	2	Steel	C35	3	3	3
35	* Spring Clip	1	Carbon Spring Steel	C45, DIN 17200	2	7	7
36	End Cap Bolt ED/ES	8	Stainless Steel	AISI 304	-	-	-
37	Limit Stop Bolt ES	2	Stainless Steel	AISI 304	-	-	-
38	Nut	2	Stainless Steel	AISI 304	-	-	-
40	Limit Stop Bolt ED	2	Stainless Steel	AISI 304	-	-	-
41	Nut	2	Stainless Steel	AISI 304	-	-	-
42	Nut Cover	2	Polyethylene	PE	-	-	-
43	* O-ring	2	Nitrile Rubber	Buna N	-	-	-
44	Insert	1	Aluminium Alloy	AlMgSi1	4	9	4
45	Threaded insert	8	Steel	9S MnPb28K	3	3	3
46	Centre-plate	1	Nylon, Glassfilled	PA6 + 25% Glass	-	-	-

* Recommended spare parts (contained in Repair kits)

Finish

- Standard : Polyester non-TGIC based powder coating
(see data sheet 4.204.01)
- CSR : CSR Coating (see data sheet 4.204.02)



www.El-O-matic.com

Copyright © Emerson Process Management. The information in this document is subject to change without notice.

Updated data sheets can be obtained from our website www.El-O-matic.com or from your nearest Valve Automation Center **USA**: +1 813 319 0266 **Europe**: +31 74 256 10 10 **Asia-Pacific**: +65 6501 4600



EMERSON
Process Management

Data sheet

Sheet No.: 1.101.30 Rev. B

Date: January 2012

CONSTRUCTION, PARTS AND MATERIALS P-SERIES ACTUATORS

P

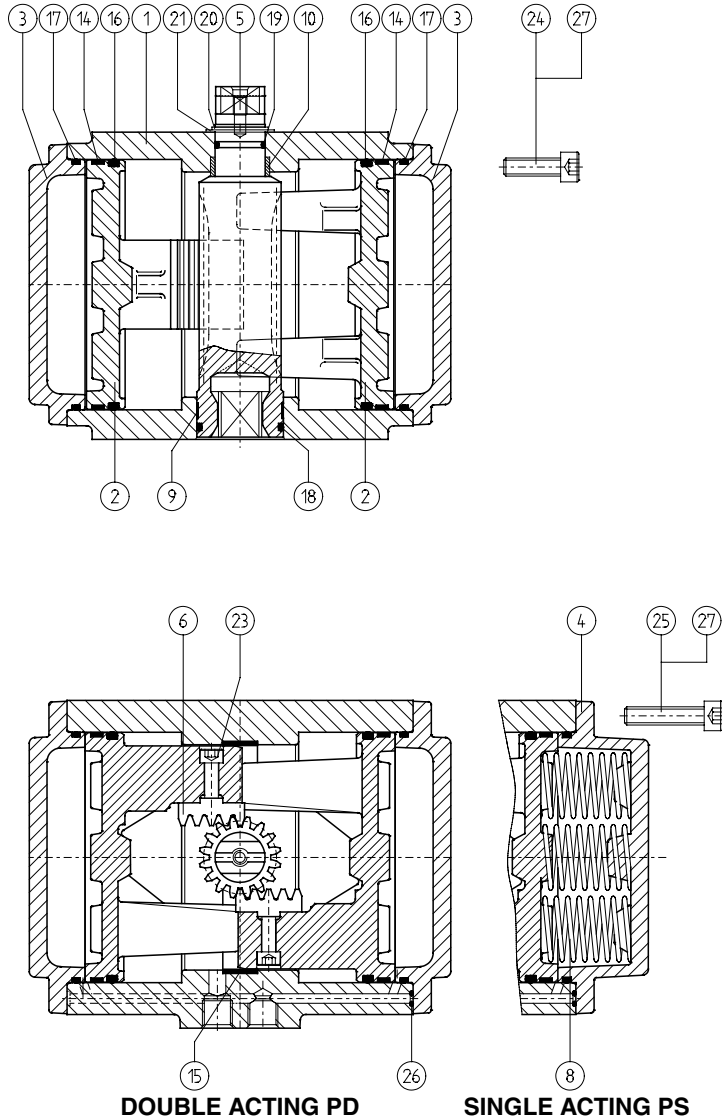

DOUBLE ACTING PD

SINGLE ACTING PS

Parts			Materials		Executions		
Nr.	Description	Qty.	Description	Specification	Std	S.S. Shaft	CSR
1	Body	1	Aluminium Alloy	GAISi10Mg, DIN 1725/2	-	-	6
2	Piston	2	Aluminium Alloy	GAISi 7Mg, DIN 1725/2	-	-	-
3	End Cap PD	2	Aluminium Alloy	GAISi10Mg, DIN 1725/2	-	-	6
4	End Cap PS	2	Aluminium Alloy	GAISi10Mg, DIN 1725/2	-	-	6
5	Central drive shaft	1	Aluminium Alloy	AlZnMgCu1.5, DIN 1725/1	1	4	4
6	Gear Rack	2	Steel	C45, DIN 17200	-	-	-
8	Spring	14	Carbon Spring Steel	Class C, DIN 17223	2	2	2
9	* Bearing Bush	1	Nylatron GS	PA6.6 + MoS2	-	-	-
10	* Bearing Bush	1	Delrin	POM	-	-	-
14	* Guide band	2	PTFE, Carbon filled	PTFE + 25% C	-	-	-
15	* Guide band	2	PTFE, Carbon filled	PTFE + 25% C	-	-	-
16	* O-ring	2	Nitrile Rubber	Buna N	-	-	-
17	* O-ring	2	Nitrile Rubber	Buna N	-	-	-
18	* O-ring	1	Nitrile Rubber	Buna N	-	-	-
19	* O-ring	1	Nitrile Rubber	Buna N	-	-	-
20	* Spring Clip	1	Carbon Spring Steel	Ck75, DIN 17222	2	5	5
21	* Thrust Washer	1	ZEDEX 100 K	-	-	-	-
23	Bolt	4	Alloy Steel	12.9 DIN 912	-	-	-
24	Endcap Bolt PD	20	Alloy Steel	8.8 DIN 912	2	4	4
25	Endcap Bolt PS	20	Alloy Steel	8.8 DIN 912	2	4	4
26	* O-ring	2	Nitrile Rubber	Buna N	-	-	-
27	Threaded insert	20	Steel	9S MnPb28K	3	3	3

* Recommended spare parts (contained in Repair kit)

Notes

- 1 Hard anodised aluminium alloy: AlZnMgCu1.5, DIN 1725/1
- 2 Deltatone® Coating
- 3 Zinc plated and passivated
- 4 Stainless Steel AISI 304

- 5 Stainless Steel, X35CrM017
- 6 CSR Coating (see 4.204.02)
- 7 P4000 has a stainless steel (AISI 304) locking ring between spring clip (20) and thrust washer (21)
- 8 P4000 has in the springs a guiding bush (PVC)

Finish

- Standard : Polyester non-TGIC based powder coating (see data sheet 4.204.01)
- CSR : CSR Coating (see data sheet 4.204.02)

EL-O-MATIC™

www.El-O-matic.com

Copyright © Emerson Process Management. The information in this document is subject to change without notice.

Updated data sheets can be obtained from our website www.El-O-matic.com or from your nearest Valve Automation Center **USA**: +1 813 319 0266 **Europe**: +31 74 256 10 10 **Asia-Pacific**: +65 6501 4600



EMERSON™
Process Management

Data sheet

Sheet No.: 1.101.60 Rev. B

Date: January 2012

CONSTRUCTION, PARTS AND MATERIALS DSA ACTUATOR

DSA

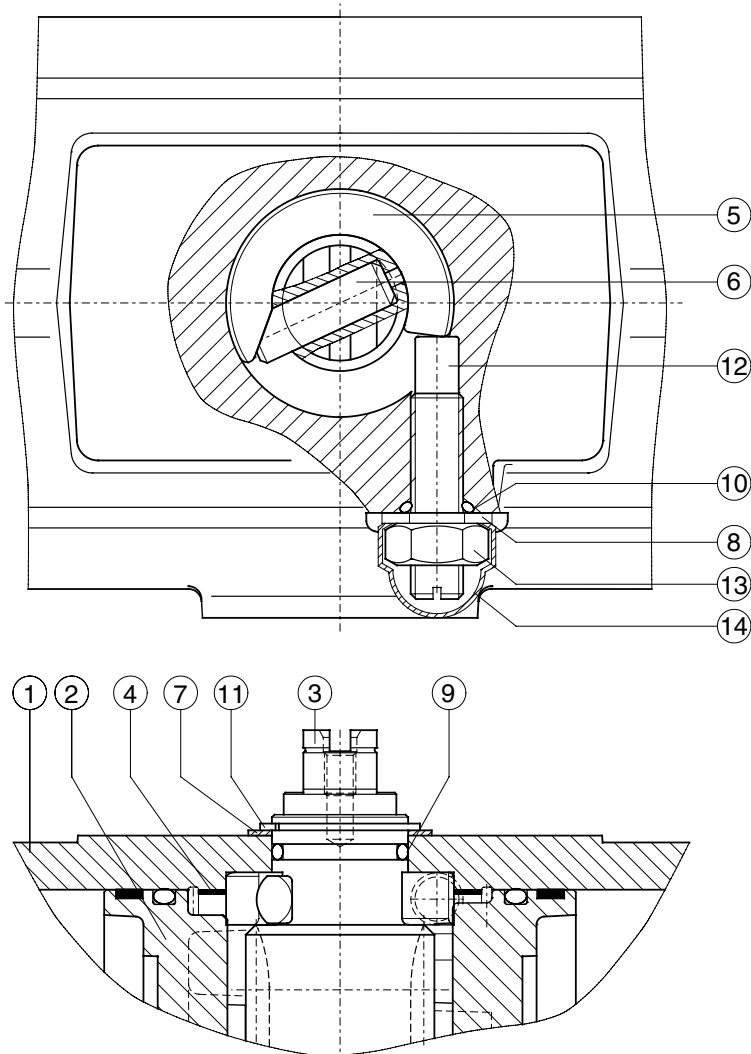

Nr.	Description	Qty.	Material	Specification	Note
1	Body DSA	1	Aluminium Alloy	GAISI10Mg, DIN 1725/2	-
2	Piston DSA	2	Aluminium Alloy	GAISI 7Mg, DIN 1725/2	-
3	Drive Shaft DSA	1	Aluminium Alloy	AlZnMgCu1.5, DIN 1725/1	1
4	* Guide Band DSA	1	Nylatron GS	PA6.6 + MoS2	-
5	Cam for stroke adj. DSA	1	Stainless Steel	AISI 304	-
6	Shaftpin for stroke adj. DSA	1	Chrome nickel steel	30CrNiMo8	-
7	* Washer	1	ZEDEX 100 K	-	-
8	* Washer	1	Nylon	PA6	-
9	* O-ring shaft top	1	Nitrile Rubber	Buna N	-
10	* O-ring limit stop bolt DSA	1	Nitrile Rubber	Buna N	-
11	Circlip	1	Carbon spring steel	Ck75, DIN17222	2
12	Limitstop bolt DSA	1	Stainless Steel	AISI 304	-
13	Nut	1	Stainless Steel	AISI 304	-
14	Nut Cover	1	Polyethylene	PE	-

* Recommended spare parts (contained in Repair kits DSA)

Finish

Polyester non-TGIC based powder coating (see data sheet 4.204.01)

Note

- 1 Hard anodised
- 2 Deltatone® coating

Remark

This data sheet shows only the extra or specific parts of a DSA actuator.
For all the other parts see data sheet 1.101.33

EL-O-MATIC™

www.El-O-matic.com

Copyright © Emerson Process Management. The information in this document is subject to change without notice.

Updated data sheets can be obtained from our website www.El-O-Matic.com or from your nearest Valve Automation Center **USA:** +1 813 319 0266 **Europe:** +31 74 256 10 10 **Asia-Pacific:** +65 6501 4600



EMERSON™
Process Management

Data sheet

Sheet No.: 1.101.70 Rev. D

Date: January 2012

LOW TEMPERATURE ACTUATOR SPECIFICATIONS

-40°C / +80°C

-40°F / +176°F

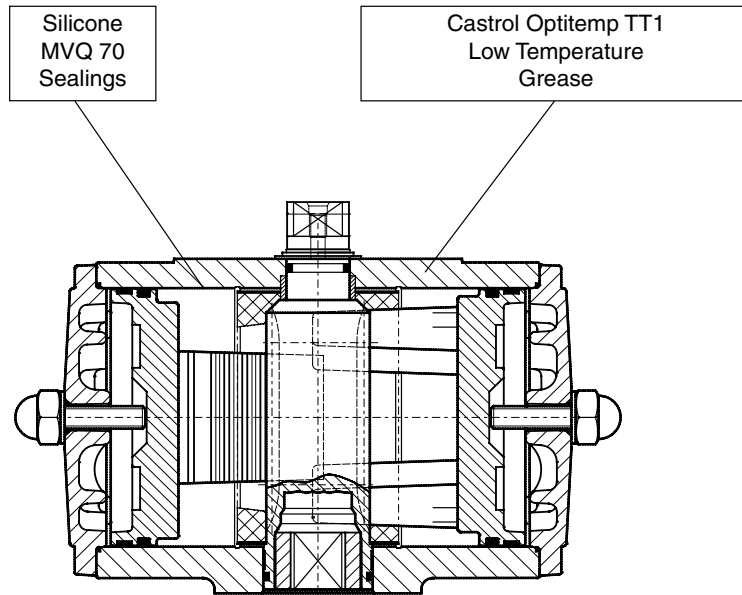

Description

A double piston, rack and pinion pneumatic actuator incorporating a three point piston support system, anti-blowout spindle and with high duty synthetic bearings at all bearing points.

This version is a standard aluminium actuator, but incorporating parts and materials suitable for low temperature operation.

Note

When operating actuators in sub-zero temperatures (< 0°C or < 32°F) care should be taken to counter the effects of freezing condensate inside the actuator.

Specification

Max. pressure : 8 bar (120 psi)

Torque : Standard

Media : Air or non corrosive gas

Temperature : -40°C to +80°C (-40°F to +176°F)

Finish : Polyester non-TGIC based powder coating (see data sheet 4.204.01)

Spare parts

Dedicated low temperature spare parts are available for maintenance or make a standard actuator suitable for low temperature operation.

Materials				
Part	Material		Specifications	Remark
Housing	Aluminium Alloy		GAISi10Mg, DIN 1725/2	
Drive Shaft	Aluminium Alloy		AlZnMgCu1.5, DIN 1725/1	Hard anodised
	Steel (180° rotation)		ETG100 or 42CrMo4V XM	Zinc Plated type > P750
	Stainless Steel		Sandvic 1802, SS2382 or X35CrM017	type > E950
Piston	Aluminium Alloy		GAISi 7Mg, DIN 1725/2	
Sealings	Silicone MVQ 70 O-rings		-/-	
Grease	Castrol Optitemp TT1		-/-	
Shaft bearings	Top :	Delrin	POM	
	Bottom :	Nylatron	PA6.6 + MoS2	
Piston bearings	PTFE		25% Carbon filled	
Body bearings	PTFE	("P" series)	25% Carbon filled	
	Nylatron	("E" series)	PA6.6 + MoS2	
Shaft thrust washer	ZEDEX 100 K		-/-	
End cap bolts	Stainless Steel	("E" series)	AISI 304 A2	
	Alloy Steel	("P" series)	8.8 DIN 912	Deltatone® coating
Springs	Carbon Spring Steel		Class C, DIN17223	Deltatone® coating

EL-O-MATIC

www.El-O-matic.com

Copyright © Emerson Process Management. The information in this document is subject to change without notice.

Updated data sheets can be obtained from our website www.El-O-matic.com or from your nearest Valve Automation Center **USA**: +1 813 319 0266 **Europe**: +31 74 256 10 10 **Asia-Pacific**: +65 6501 4600



EMERSON
Process Management

Data sheet

Sheet No.: 1.101.71 Rev. C

Date: January 2012

HIGH TEMPERATURE ACTUATOR SPECIFICATIONS

-20°C / +120°C

-4°F / +248°F

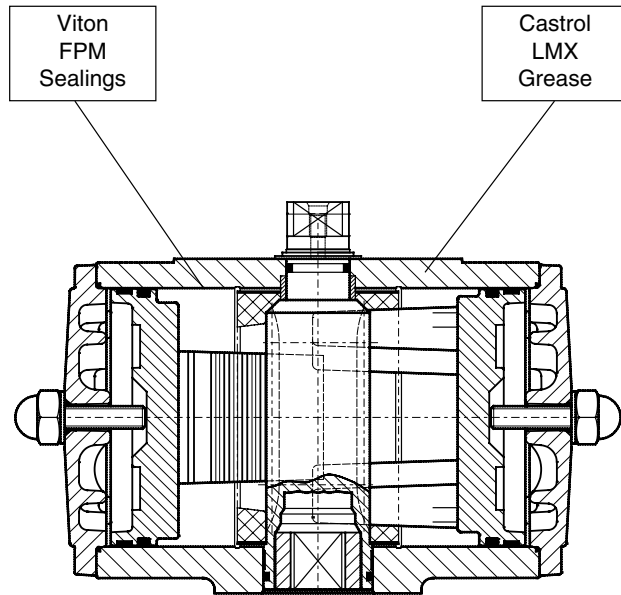

Description

A double piston, rack and pinion pneumatic actuator incorporating a three point piston support system, anti-blowout spindle and with high duty synthetic bearings at all bearing points.

This version is a standard aluminium actuator, but incorporating parts and materials suitable for high temperature operation.

Specification

Max. pressure : 8 bar (120 psi)
 Torque : Standard
 Media : Air or non corrosive gas
 Temperature : -20°C to +120°C (-4°F to +248°F)

Spare parts

Dedicated high temperature spare parts are available for maintenance or make a standard actuator suitable for high temperature operation.

Materials				
Part	Material		Specifications	Remark
Housing	Aluminium Alloy		GAISi10Mg, DIN 1725/2	
Drive Shaft	Aluminium Alloy		AlZnMgCu1.5, DIN 1725/1	Hard anodised
	Steel (180° rotation)		ETG100 or 42CrMo4V XM	Zinc Plated type > P750
	Stainless Steel		Sandvic 1802, SS2382 or X35CrM017	type > E950
Piston	Aluminium Alloy		GAISi 7Mg, DIN 1725/2	
Sealings	Viton FPM O-rings		-/-	
Grease	Castrol LMX		-/-	
Shaft bearings	Top :	Delrin	POM	
	Bottom :	Nylatron	PA6.6 + MoS2	
Piston bearings	PTFE		25% Carbon filled	
Body bearings	PTFE	("P" series)	25% Carbon filled	
	Nylatron	("E" series)	PA6.6 + MoS2	
Shaft thrust washer	ZEDEX 100 K		-/-	
End cap bolts	Stainless Steel	("E" series)	AISI 304 A2	
	Alloy Steel	("P" series)	8.8 DIN 912	Deltatone® coating
Springs	Carbon Spring Steel		Class C, DIN17223	Deltatone® coating

EL-O-MATIC™

www.El-O-matic.com

Copyright © Emerson Process Management. The information in this document is subject to change without notice.

Updated data sheets can be obtained from our website www.El-O-Matic.com or from your nearest Valve Automation Center **USA:** +1 813 319 0266 **Europe:** +31 74 256 10 10 **Asia-Pacific:** +65 6501 4600



EMERSON™
 Process Management

Data sheet

Sheet No.: 4.201 Rev. A

Date: November 2009

INSTALLATION OF SPRINGS OF P-SERIES ACTUATOR

P

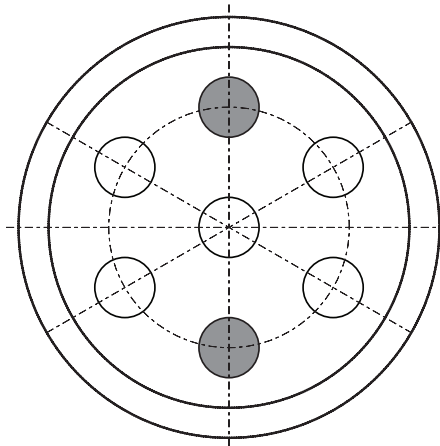

4 SPRINGS

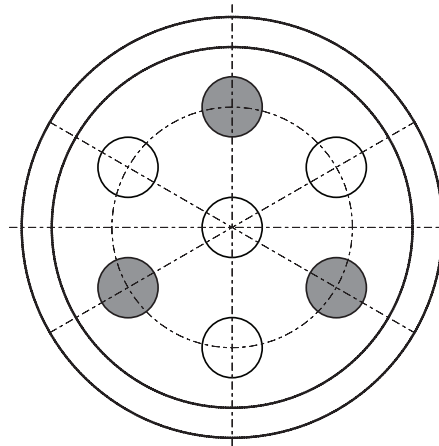

6 SPRINGS

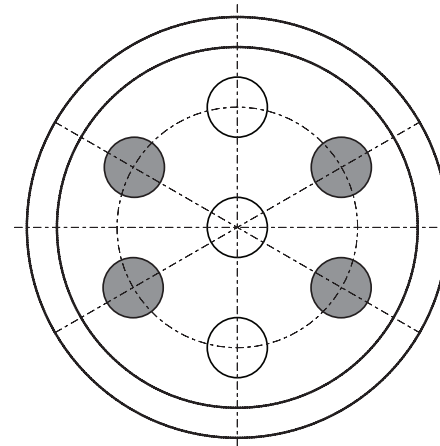

8 SPRINGS

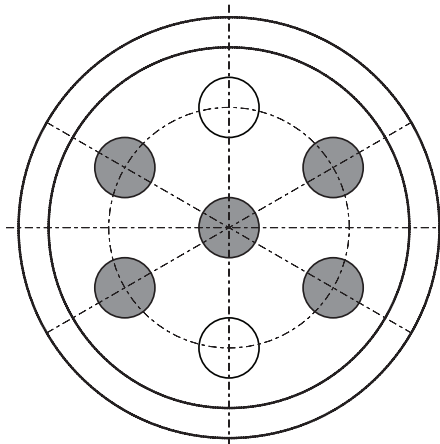

10 SPRINGS

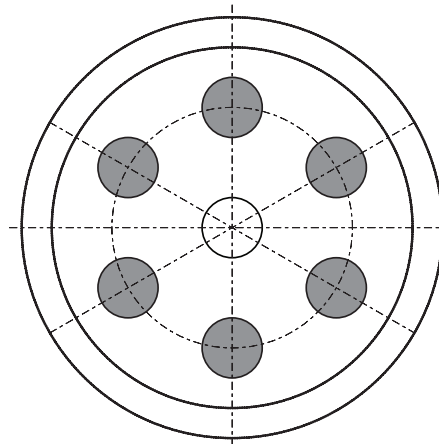

12 SPRINGS

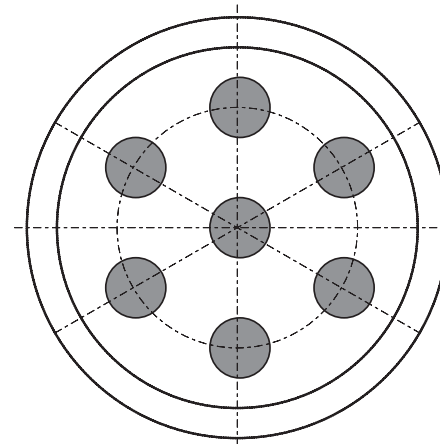

14 SPRINGS



SPRING



www.El-O-matic.com

Copyright © Emerson Process Management. The information in this document is subject to change without notice.

Updated data sheets can be obtained from our website www.El-O-matic.com or from your nearest Valve Automation Center **USA:** +1 813 319 0266 **Europe:** +31 74 256 10 10 **Asia-Pacific:** +65 6501 4600



EMERSON
Process Management

Data sheet

Sheet No.: 4.202 Rev. A

Date: November 2009

INSTALLATION OF SPRINGS OF E-SERIES ACTUATOR

E

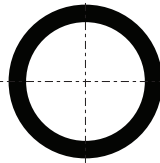

SPRING SET No. 1
inner spring

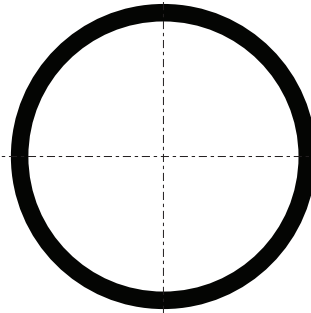

SPRING SET No. 2
mid spring

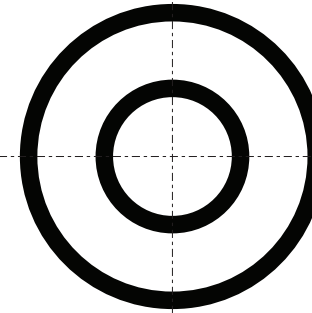

SPRING SET No. 3
inner spring
mid spring

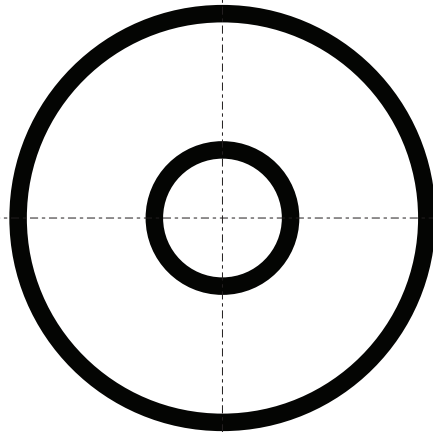

SPRING SET No. 4
inner spring
outer spring

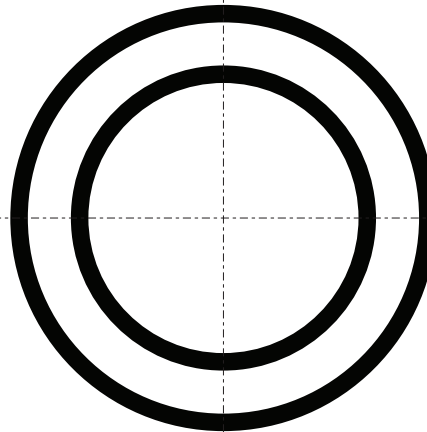

SPRING SET No. 5
mid spring
outer spring

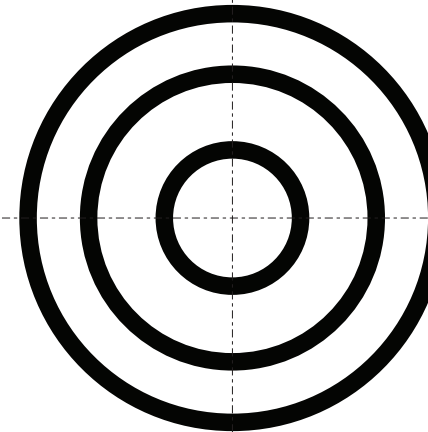

SPRING SET No. 6
inner spring
mid spring
outer spring



www.El-O-matic.com

Copyright © Emerson Process Management. The information in this document is subject to change without notice.

Updated data sheets can be obtained from our website www.El-O-matic.com or from your nearest Valve Automation Center **USA:** +1 813 319 0266 **Europe:** +31 74 256 10 10 **Asia-Pacific:** +65 6501 4600



EMERSON
Process Management

Data sheet

Sheet No.: 1.503 Rev. A
Date: November 2009

DOUBLE ACTING ACTUATOR ASSEMBLY MODES

E/P

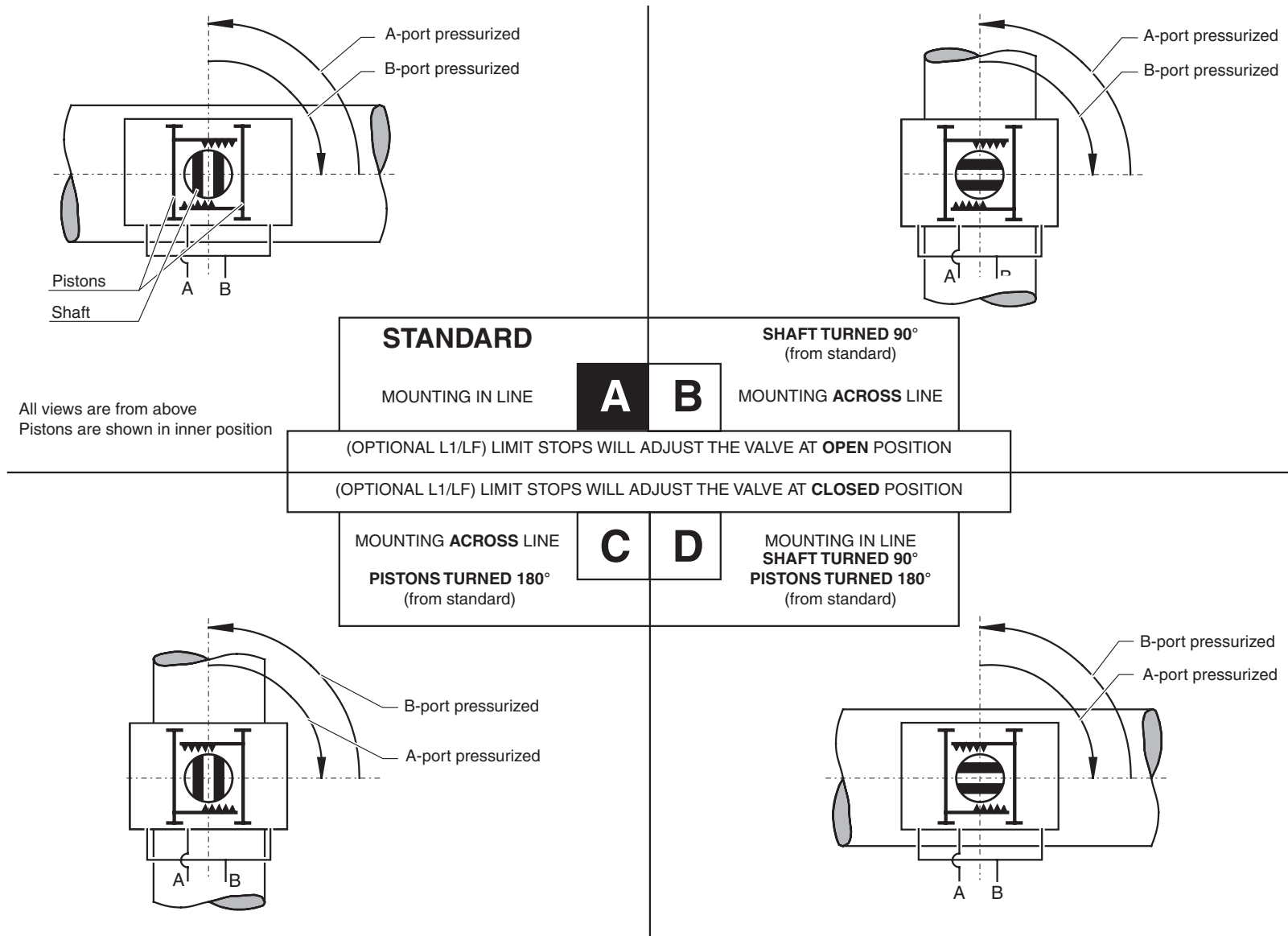

www.El-O-matic.com

Copyright © Emerson Process Management. The information in this document is subject to change without notice.

Updated data sheets can be obtained from our website www.El-O-matic.com or from your nearest Valve Automation Center **USA:** +1 813 319 0266 **Europe:** +31 74 256 10 10 **Asia-Pacific:** +65 6501 4600



EMERSON
Process Management

Data sheet

Sheet No.: 1.504 Rev. A
Date: November 2009

SPRING RETURN ACTUATOR ASSEMBLY MODES

E/P

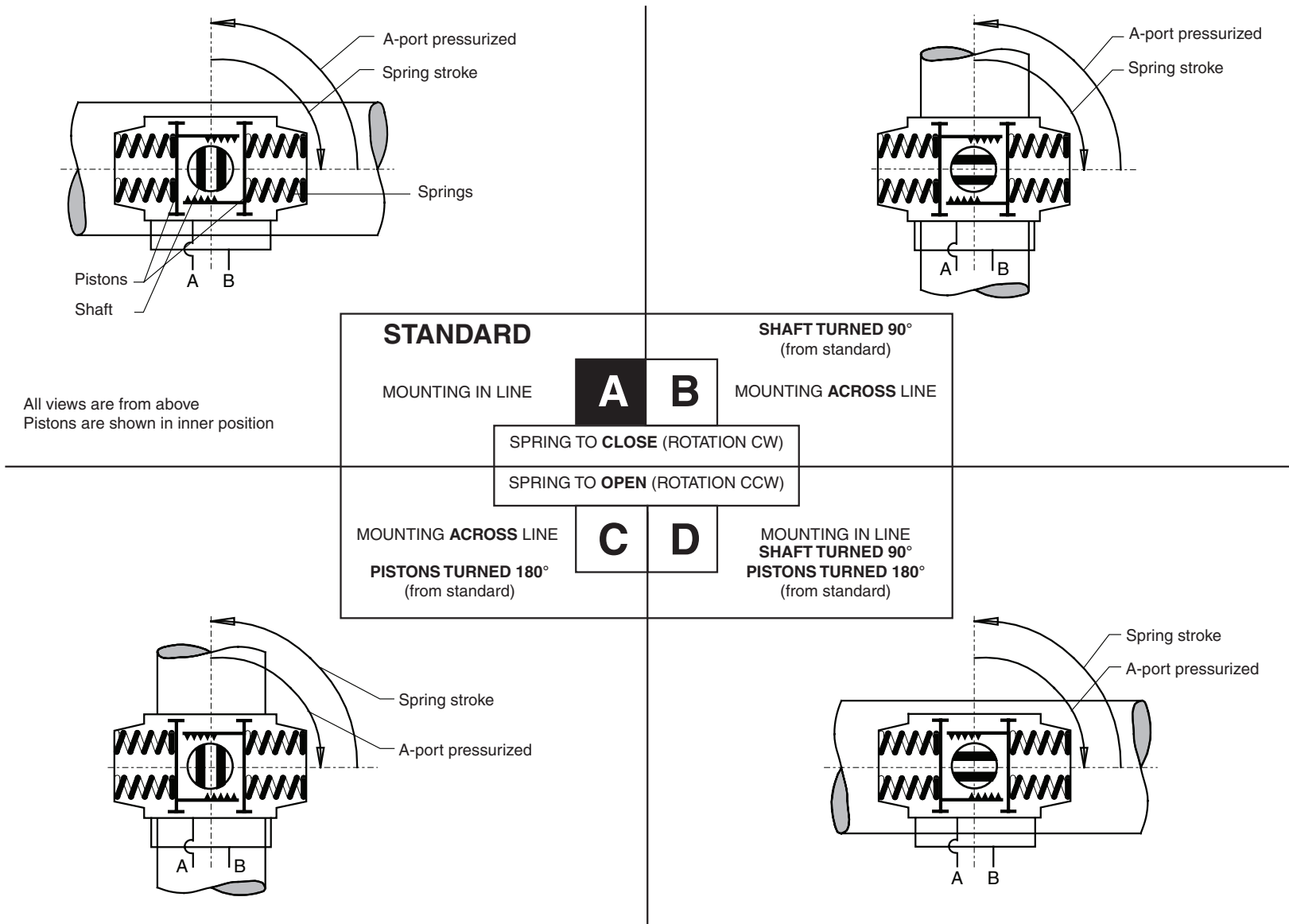

www.El-O-matic.com

Copyright © Emerson Process Management. The information in this document is subject to change without notice.

Updated data sheets can be obtained from our website www.El-O-matic.com or from your nearest Valve Automation Center **USA:** +1 813 319 0266 **Europe:** +31 74 256 10 10 **Asia-Pacific:** +65 6501 4600



EMERSON
Process Management

Data sheet

Sheet No.: 4.204.01 Rev. B

Date: April 2011

EL-O-MATIC STANDARD CORROSION PROTECTION SYSTEM

**High grade aluminium alloy,
hard anodised**
(Option : Stainless steel)

Stainless steel fasteners

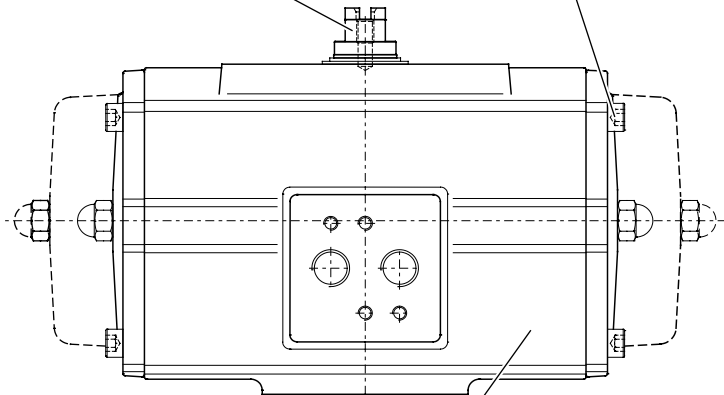

Powder coating:
Polyester non-TGIC based powder
coating for exterior use

Description

The corrosion protection system of standard EL-O-Matic E&P series pneumatic actuators consist of the following treatments or materials:

1 Pre-treatment

All aluminium parts get a chromate treatment prior to painting. This chromate pre-treatment takes care of a perfect bonding of the paint layer to the aluminium housing and gives additional corrosion protection to the bore of the housing.

2 Powder coating

- Polyester non-TGIC based powder coating for exterior use.
 - The powder coating is applied cold using automatic electrostatic spray equipment and is cured at minimum 190°C (374°F) offering excellent anti color fade and weather resistance.
 - The powder coating thickness is 80µm (3.15 mils) minimum, and 160µm (6.3 mils) maximum.
 - Good resistance against most chemical bases, acids, solvents, alkalis and oils at normal temperatures.
 - Excellent exterior mechanical durability.
 - The coating has passed a salt spray test according to ASTM B117 for 500 hours.
- The powder coating is virtually solvent free, and therefore environmentally friendly.

3 High grade & hard anodised aluminium pinion

Actuators with high grade & hard anodised aluminium pinions, passed a 500 hours salt spray test. Optional stainless steel pinions are available for a higher corrosion resistance.

4 Stainless steel or Deltatone treated external steel parts

External parts are stainless steel or steel alloy with a Deltatone® treatment.

Technical data

Coating	: Polyester non-TGIC based powder coating
Salt spray test	: DIN 50021 / ASTM B117: 500 hours
Color	: Yellow (RAL 1007)
Materials	: Housing : Aluminium alloy
	: Pinion : High grade aluminium alloy, hard anodised (Option : Stainless steel)
	: Fasteners : Stainless steel or alloy steel with Deltatone® treatment
	: Tagplate : Stainless steel
Application	: Standard EL-O-MATIC E & P series pneumatic actuators For Non-Standard actuators, see data sheet 4.204.05
Option	: CSR coating for excellent corrosion resistance See data sheet 4.204.02

EL-O-MATIC™

www.El-O-matic.com

Copyright © Emerson Process Management. The information in this document is subject to change without notice.

Updated data sheets can be obtained from our website www.El-O-Matic.com or from your nearest Valve Automation Center **USA**: +1 813 319 0266 **Europe**: +31 74 256 10 10 **Asia-Pacific**: +65 6501 4600



EMERSON™
Process Management

Data sheet

Sheet No.: 4.204.02 Rev. A

Date: November 2009

EL-O-MATIC ACTUATOR WITH CSR COATING

CSR

Hard anodised aluminium
(Option : Stainless steel)

Stainless steel fasteners

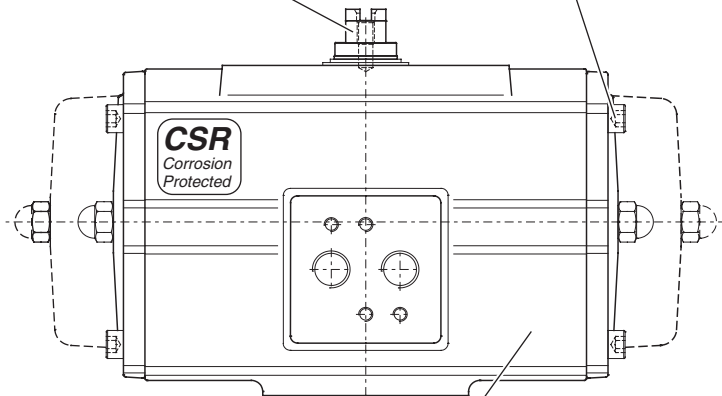

Coating:
20 microns Ceramic filled epoxy resin

Description

EL-O-MATIC CSR-actuators have an excellent corrosion resistance in environments where the actuator is in contact with chemicals like caustic soda. The CSR coating itself is resistant to at least 1000 hours of salt spray test exposure. Together with the excellent mechanical properties, the CSR coating is "the" solution for very harsh environments.

CSR actuator housing and caps are completely coated (inside and out) with a ceramic filled fluoropolymer based epoxy resin, impregnated by a temperature of 240°C into the aluminium surface.

Approximately 40% of the coating is impregnated into the aluminium, 60% stays on the surface of the component as a seal.

Technical data

Coating	: Ceramic filled fluoropolymer based epoxy resin
Layer thickness	: 20 microns
Salt spray test	: DIN 50021 / ASTM B117: 1000 hours
Max. temperature	: -20° to + 80°C
Materials	: Housing : Aluminium alloy
	: Shaft : Aluminium hard anodised
	: (Option : Stainless steel)
	: Fasteners : Stainless steel
	: Tagplate : Stainless steel
Application	: Optional on all EL-O-MATIC actuators

Chemical resistances

Resistance to various inorganic chemicals, organic chemicals, gasolines, oils, detergents, etc. is generally good to excellent, but also depends on temperature and/or concentration. More detailed information available at data sheet 4.204.021

EL-O-MATIC™

www.El-O-matic.com

Copyright © Emerson Process Management. The information in this document is subject to change without notice.

Updated data sheets can be obtained from our website www.El-O-Matic.com or from your nearest Valve Automation Center **USA:** +1 813 319 0266 **Europe:** +31 74 256 10 10 **Asia-Pacific:** +65 6501 4600



EMERSON™
Process Management

Data sheet

Sheet No.: 4.204.021 Rev. A

Date: November 2009

CHEMICAL RESISTANCE LIST FOR CSR COATING

CSR

Inorganic chemicals

1	Ammonium hydroxide (10%)	2
1	Calcium chloride (~50%)	3
3	Chlorine	1
3	Chromic acid	1
3	Hydrofluoric acid (50%)	1
1	Caustic potash solution (10%)	3
1	Sodium hypochlorite (saturated)	2
1	Caustic soda solution (10%)	1
1	Caustic soda solution (saturated)	2
1	Phosphoric acid (10%)	1
1	Phosphoric acid (50%)	

Organic chemicals

3	Acetone	1	Glycerine
3	Acetonitrile	1	Hexane
3	Aniline	1	Isooctane
2	Benzene	1	Isopropanol
1	n-Butanol	1	Methanol
3	Butyl acetate	3	Methylene chloride
3	Chlorobenzene	3	Methyl ethyl ketone
3	Chloroforme	3	N.N-Dimethylformamide
3	o-Chlorophenol	3	N-Methylpyrrolidon
1	Cyclohexane	1	Oxalic acid
3	Cyclohexanone	1	Perchloroethylene
3	1,2-Dichloroethane	1	Petroleum ether
2	Diethyl ether	3	Phenol
2	Dioxane	1	Carbon bisulphide
1	Glacial acetic acid	1	Turpentine
1	Ethanol	2	Tetrachloroethane
3	Ethyl acetate	2	1,1,1-Trichloroethane
1	Ethylene glycol	1	Tetrachloromethane
1	Formaldehyde	3	Trichloroethylene
2	Freon 11	2	Toluene
2	Freon 22	1	Xylene
1	Excellent		
2	Limited resistance; it is recommended to perform field tests under the specified conditions.		
3	Not recommended		

Fuels/lubricants

1	Two-star petrol (50°C)
1	Four-star petrol (50°C)
1	Fuel M 15 (50°C)
1	Diesel oil
1	Kerosene
1 to 2	Hypoid bevel gear oil Shell Spirax HD 90 (150°C)
1	Transmission oil Shell Spirax MA 80 (150°C)

Chemicals

1	Automatic transmission fluid Shell Dextra 11D 20-137 (150°C)
1	Engine oil, mineral, Mihag 1500-40 (150°C)
1	Engine oil, synthetic, Mobil SHC 10 W-40
3	Brake fluid Hydraulan DOT 4
1	Roller bearing grease DIN 51 825

Technical detergents

2	Genkeene
2	1,1,1-Trichloroethane
2	Triklone A
2	Perchloroethylene

Miscellaneous fluids

1	Glysantin (BASF)/water
1	Plasticizer DOP
1	Suds
1	Washing-up liquids
1	Household detergents
1	Linseed oil
1	Milk
1	Soapsuds
1	Silicone oils

Note: This list has been composed with great care. However, EL-O-MATIC cannot be held responsible, either for any errors in this list or for their consequences. Because of continued testing this list is subject to change without notice.

EL-O-MATIC™

www.El-O-matic.com

Copyright © Emerson Process Management. The information in this document is subject to change without notice.

Updated data sheets can be obtained from our website www.El-O-Matic.com or from your nearest Valve Automation Center **USA:** +1 813 319 0266 **Europe:** +31 74 256 10 10 **Asia-Pacific:** +65 6501 4600



EMERSON™
Process Management

Data sheet

Sheet No.: 1.203.011 Rev. A
Date: November 2009

DIMENSION SHEET STANDARD 180° ACTUATOR

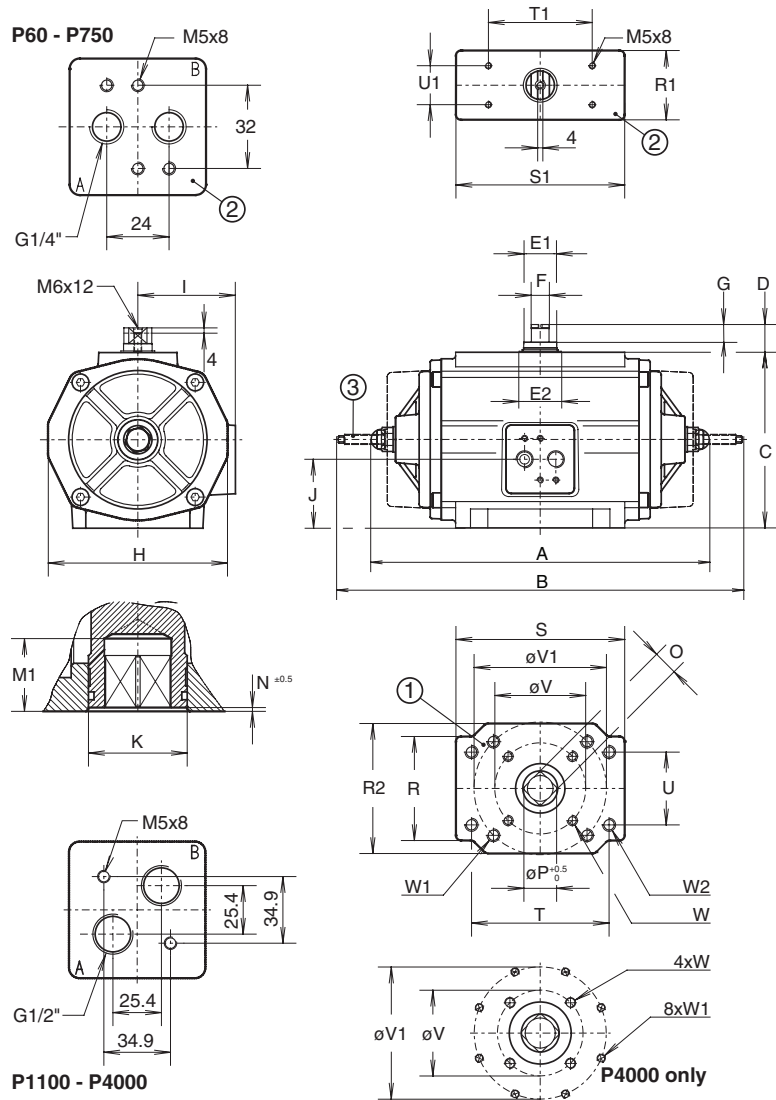
180°



Dim. in mm.	ACTUATOR TYPE								
	E12	P60	P150	P280	P500	P750	P1100	P2500	P4000
A DA	233	295	354	414	447	502	633	752	
B SR	256	332	434	497	553	641	817	1091	
C	101	135	160	190	234	247	356	380	
D	20	20	20	30	30	30	30	30	
E1	16	22	26	36	36	45	55	64	
E2	23	30	35	45	45	55	65	80	
F	10	14	14	19	19	30	36	36	
G	12	12	12	19	19	10	10	10	
H	101	138	168	192	239	250	344	372	
I	58	75	89	109	134	135	183	200	
J	43	53	69	95	116	125	178	190	
K	28	38	48	56	56	75	85	120	
M1	27	27	31	38	38	51	66	77	
N	1	1	1.5	1.5	2	2.5	3	1.5	
O max.	14.11	17.11	22.13	27.13	27.13	36.16	46.16	55.19	
O min.	14.00	17.00	22.00	27.00	27.00	36.00	46.00	55.00	
P	18.1	25.2	28.2	36.2	36.2	48.2	60.2	72.2	
R	60	80	101	111	140	140	170	170	
R1	51	60	71	81	100	120	160	160	
R2	70	100	-	-	-	-	-	262	
S	111	130	141	161	210	210	290	290	
S1	111	130	141	141	160	210	245	245	
T	-	-	-	-	-	-	234.6	-	
T1	80	80	80	130	130	130	130	130	
U	-	-	-	-	-	-	97.2	-	
U1	30	30	30	30	30	30	30	30	
V	F05	F07	F07	F10	F10	F14	F16	F16	
W	50	70	70	102	102	140	165	165	
W1	M6x9	M8x13	M8x13	M10x16	M10x16	M16x20	M20x30	M20x30	
W2	F07	F10	F10	F12	F12	-	-	F25	
W3	70	102	102	125	125	-	-	254	
W4	M8x13	M10x16	M10x16	M12x16	M12x16	-	-	M16x25	
W5	-	-	-	-	-	-	M16x25	-	

For E12 dimensions see 1.103.102

Note

1. Flange to ISO 5211, square drive to DIN 3337
2. Top and Solenoid flange to VDI/VDE 3845 (NAMUR).
P1100 P2500 and P4000 have a non-NAMUR solenoid flange with 1/2" entries.
3. 180° actuators are standard equipped with "L1" limit stops. 120° or 135° rotation is possible with optional LF-option (See data sheet 1.501.01)



www.El-O-matic.com

Copyright © Emerson Process Management. The information in this document is subject to change without notice.

Updated data sheets can be obtained from our website www.El-O-matic.com or from your nearest Valve Automation Center **USA:** +1 813 319 0266 **Europe:** +31 74 256 10 10 **Asia-Pacific:** +65 6501 4600



EMERSON
Process Management

Data sheet

Sheet No.: 1.204.01 Rev. A

Date: November 2009

180° DOUBLE ACTING ACTUATOR TORQUE (Nm.)

180°

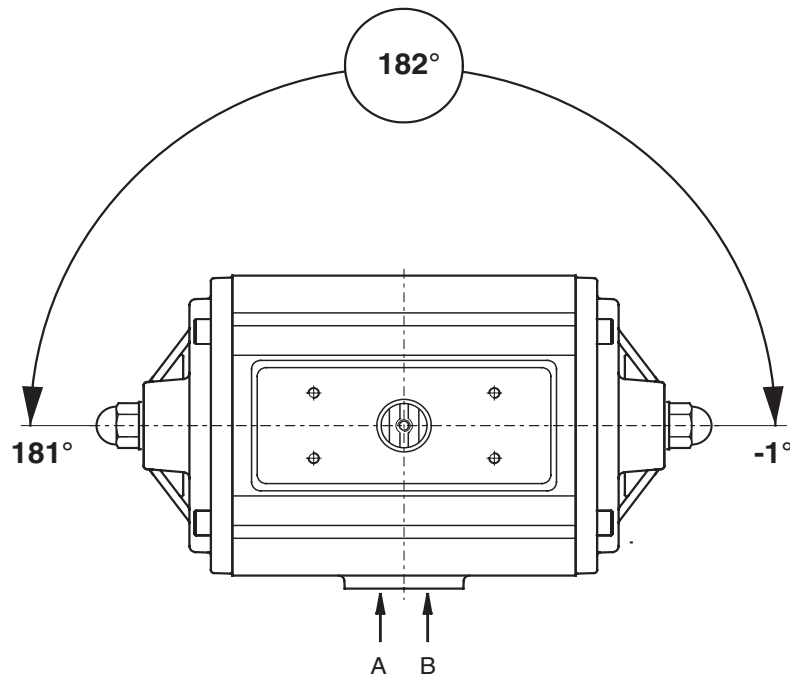
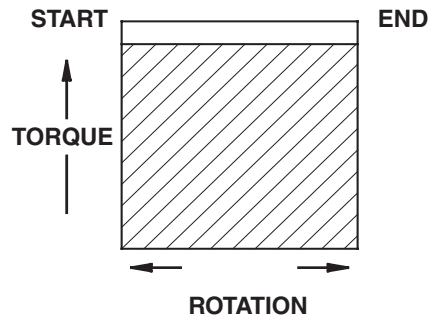

Actuator type	Torque in Nm Supply Pressure (bar)						
	2	3	4	4.5	5	5.5	6
ED 12	4.8	7.3	9.7	10.9	12.2	13.4	14.6
PD 60	11	17	23	26	29	32	35
PD 150	29	43	58	65	73	80	87
PD 280	54	81	109	123	137	150	164
PD 500	95	144	193	217	242	266	290
PD 750	142	214	287	323	359	395	432
PD 1100	209	316	423	476	530	583	637
PD 2500	481	728	974	1098	1221	1344	1468
PD 4000	812	1228	1645	1853	2061	2269	2477

Note

- Emerson Process Management recommends that the valve manufacturer supply the maximum required torque values (Including any adjustments or suggested safety factors for valve service conditions or application).
Additionally, the valve manufacturer must identify at which position(s) and direction(s) of rotation (Counter Clock Wise or Clock Wise) these maximum requirements occur.
- If in doubt, or you require any assistance with sizing actuators, do not hesitate to contact your nearest Emerson's Valve Automation Division representative.
- Pressure on port "A" opens the actuator*
- The actuator is shown in closed position*
- Do not exceed the maximum supply pressure of 6 bar.
(*code A, data sheet 1.503)

EL-O-MATIC™

www.El-O-matic.com

Copyright © Emerson Process Management. The information in this document is subject to change without notice.

Updated data sheets can be obtained from our website www.El-O-matic.com or from your nearest Valve Automation Center **USA:** +1 813 319 0266 **Europe:** +31 74 256 10 10 **Asia-Pacific:** +65 6501 4600



EMERSON™
Process Management

Data sheet

Sheet No.: 1.204.02 Rev. A
Date: November 2009

180° SPRING RETURN ACTUATOR TORQUE (Nm.)

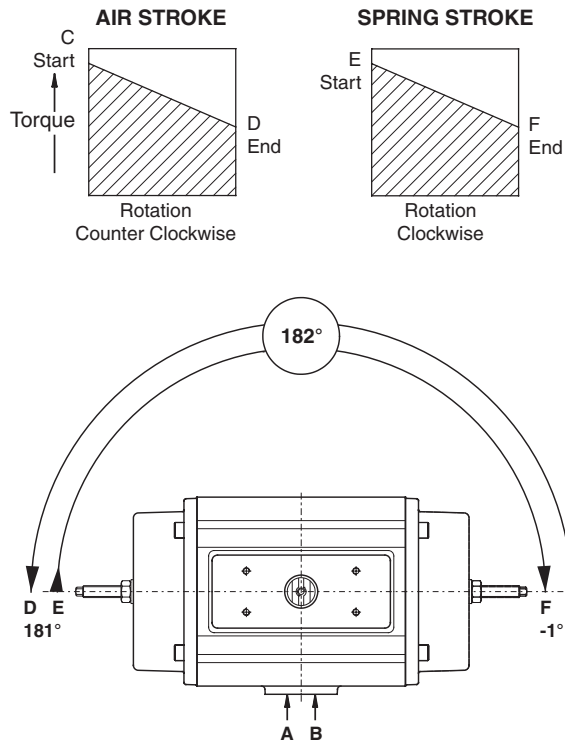
180°



Note

- Emerson Process Management recommends that the valve manufacturer supply the maximum required torque values (Including any adjustments or suggested safety factors for valve service conditions or application).
Additionally, the valve manufacturer must identify at which position(s) and direction(s) of rotation (Counter Clock Wise or Clock Wise) these maximum requirements occur.
- If in doubt, or you require any assistance with sizing actuators, do not hesitate to contact your nearest Emerson's Valve Automation Division representative.
- Pressure on port "A" opens the actuator*
- The actuator is shown in closed position*
- Do not exceed the maximum supply pressure of 6 bar.
(*code A, data sheet 1.504)

Actuator type	Spring nr.	Air Stroke (Nm)												Spring Stroke (Nm)				
		SUPPLY PRESSURE																
		3		3.5		4		4.5		5		5.5		6		E	F	
ES 12	2	-	-	3.8	1.1	5.2	2.4	6.5	3.7	7.8	5.0	9.1	6.3	10.4	7.6	7.1	4.5	
	PE 60	8	9	4	12	6	15	9	18	12	21	15	24	18	27	21	13	7
		10	-	-	10	3	13	6	16	9	19	12	22	15	25	18	16	9
		12	-	-	-	-	11	3	14	5	17	8	20	11	23	14	19	11
PE 150	8	24	12	32	19	39	27	46	34	54	41	61	49	68	56	29	17	
	10	20	4	27	12	34	19	42	26	49	34	56	41	64	48	36	21	
	12	-	-	22	4	30	11	37	19	44	26	52	33	59	40	44	25	
	14	-	-	-	-	25	3	32	11	40	18	47	25	54	33	51	30	
PE 280	8	43	9	57	23	71	37	85	51	99	65	112	78	126	92	67	34	
	10	-	-	48	5	61	19	75	33	89	47	103	60	117	74	84	43	
	12	-	-	-	-	-	-	66	15	80	29	93	42	107	56	101	51	
	14	-	-	-	-	-	-	-	-	70	11	84	24	98	38	118	60	
PE 500	8	-	-	112	31	136	56	160	80	185	105	209	129	-	-	128	51	
	10	-	-	-	-	122	22	146	46	171	70	195	95	219	119	160	64	
	12	-	-	-	-	-	-	-	-	156	36	181	61	205	85	192	77	
	14	-	-	-	-	-	-	-	-	-	-	167	26	191	51	224	89	
PE 750	8	134	29	170	66	206	102	242	138	279	175	-	-	-	-	173	72	
	10	-	-	150	20	186	56	222	92	259	128	295	165	331	201	216	91	
	12	-	-	-	-	-	-	202	46	239	82	275	119	311	155	259	109	
	14	-	-	-	-	-	-	-	-	218	36	255	72	291	109	302	127	
PE1100	8	190	74	244	128	297	181	351	235	404	288	458	342	-	-	226	113	
	10	-	-	212	68	266	121	319	175	373	228	426	282	480	335	282	141	
	12	-	-	-	-	234	61	288	114	341	168	395	221	448	275	339	170	
	14	-	-	-	-	-	-	257	54	310	107	364	161	417	214	395	198	
PS2500	8	356	160	479	283	602	406	724	528	847	651	970	774	1093	897	528	332	
	10	-	-	387	142	510	265	632	387	755	510	878	633	1001	756	660	414	
	12	-	-	-	-	417	123	540	246	663	369	786	492	909	615	792	497	
	14	-	-	-	-	-	-	448	105	571	228	694	351	816	473	924	580	
PS4000	8	606	276	814	484	1023	692	1231	900	1439	1108	1647	1316	1855	1524	891	560	
	10	-	-	659	246	867	454	1075	662	1283	870	1492	1078	1700	1286	1114	699	
	12	-	-	-	-	712	216	920	424	1128	632	1336	840	1544	1048	1337	839	
	14	-	-	-	-	-	-	764	186	973	394	1181	602	1389	810	1560	979	



www.El-O-matic.com

Copyright © Emerson Process Management. The information in this document is subject to change without notice.

Updated data sheets can be obtained from our website www.El-O-Matic.com or from your nearest Valve Automation Center **USA:** +1 813 319 0266 **Europe:** +31 74 256 10 10 **Asia-Pacific:** +65 6501 4600



EMERSON
Process Management

Contact Us: Emerson Process Management, Valve Automation facilities at your nearest location:

NORTH & SOUTH AMERICA

18703 GH Circle
PO Box 508
Waller, TX 77484
USA
T +1 281 727 5300
F +1 281 727 5353

2500 Park Avenue West
Mansfield, OH 44906
USA
T +1 419 529 4311
F +1 419 529 3688

9009 King Palm Drive
Tampa, FL 33619
USA
T +1 813 630 2255
F +1 813 630 9449

13840 Pike Road
Missouri City, Texas 77489
USA
T +1 281 499 1561
F +1 281 499 8445

Av. Hollingsworth,
325, Iporanga Sorocaba,
SP 18087-105
Brazil
T +55 15 3238 3788
F +55 15 3228 3300

MIDDLE EAST & AFRICA

P. O. Box 17033
Dubai
United Arab Emirates
T +971 4 811 8100
F +971 4 886 5465

P. O. Box 105958
Abu Dhabi
United Arab Emirates
T +971 2 697 2000
F +971 2 555 0364

P. O. Box 3911
Al Khobar 31952
Saudi Arabia
T +966 3 814 7560
F +966 3 814 7570

P. O. Box 10305
Jubail 31961
Saudi Arabia
T +966 3 340 8650
F +966 3 340 8790

P. O. Box 32281
Doha
Qatar
T +974 4 576777
F +974 4 315448

2 Monteer Road, Isando
Kempton Park, 1600
South Africa
T +27 11 974 3336
F +27 11 974 7005

EUROPE

Asveldweg 11
7556 BR Hengelo (O)
The Netherlands
T +31 74 256 1010
F +31 74 291 0938

Siemensring 112
47877 Willich
Germany
T +49 2154 499 660
F +49 2154 499 6613

25, Rue de Villeneuve
Silic – BP 40434
94583 Rungis
France
T +33 1 49 79 73 00
F +33 1 49 79 73 99

Via Montello 71/73
20038 Seregno (Milan)
Italy
T +39 0362 2285 207
F +39 0362 2436 55

6 Bracken Hill
South West Industrial Estate
Peterlee SR8 2LS
United Kingdom
T +44 191 518 0020
F +44 191 518 0032

2A Szturmowa Str
02-678 Warsaw
Poland
T +48 22 45 89 237
F +48 22 45 89 231

C/ Francisco Gervás, 1
28108 Alcobendas – Madrid
Spain
T +34 0913 586 000
F +34 0913 589 145

Letnikovskaya Str. 10-2
115114 Moscow
Russia and FSU
T +7 495 981 98 11
F +7 495 981 98 10

ASIA PACIFIC

No. 9 Gul Road
#01-02 Singapore 629361
T +65 6501 4600
F +65 6268 0028

9/F Gateway Building
No. 10 Ya Bao Road
Chaoyang District
Beijing 100020
P.R.China
T +86 10 5821 1188
F +86 10 5821 1100

No.15 Xing Wang Road
Wuqing Development Area
Tianjin 301700
P.R.China
T +86 22 8212 3300
F +86 22 8212 3308

Lot 13112, Mukim Labu
Kawasan Perindustrian Nilai
71807 Nilai, Negeri Sembilan
Malaysia
T +60 6 799 2323
F +60 6 799 9942

471 Mountain Highway
Bayswater, Victoria 3153
Australia
T +61 3 9721 0200
F +61 3 9720 0588

Delphi B Wing, 601 & 602
6th Floor, Central Avenue
Powai, Mumbai – 400 076
India
T +91 22 6662 0566
F +91 22 6662 0500

NOF, Shinagawa Konan Bldg
1-2-5, Higashi-shinagawa
Shinagawa-ku, Tokyo
140-0002 Japan
T +81 3 5769 6873
F +81 3 5769 6902

© 2012 Emerson Process Management. All rights reserved.

The Emerson logo is a trademark and service mark of Emerson Electric Co. "Brand mark listing" are marks of one of the Emerson Process Management family of companies.

All other marks are property of their respective owners.

The contents of this publication are presented for information purposes only, and while every effort has been made to ensure their accuracy, they are not to be construed as warranties or guarantees, express or implied, regarding the products or services described herein or their use or applicability. All sales are governed by our terms and conditions, which are available on request. We reserve the right to modify or improve the designs or specifications of our products at any time without notice.

EL-O-MATIC® is a registered trademark of EL-O-MATIC B.V.

EL-O-MATIC™

www.El-O-matic.com



EMERSON™
Process Management